

Simple and Effective, The Tri-Clover® Ball Valve

5308/5309 Series Ball Valves

Application

Tri-Clover ball valves are ideal for applications requiring a full flow body design to minimize line turbulence and pressure drop. An encapsulated seat option is available for critical process applications requiring maximum reduction of potential for product entrapment.

Standard Design

The Tri-Clover ball valve consists of a stainless steel body that houses a rotating ball. The rotating ball is sealed in the body with a PTFE seat that either partially or fully encapsulates the ball. The valve is activated by a stainless steel handle that opens and closes the valve through a quarter turn. The valve can also be operated by an optional ¼ turn pneumatic actuator. External thrust springs maintain constant pressure on the stem packing. The stem and packing design eliminate the possibility of the stem becoming dislodged or blown out.

Actuator Function

- Pneumatic actuator air to air
- Pneumatic actuator air to spring

Materials

Elastomers	PTFE (standard) Reinforced PTFE (optional)
Valve Body	.316L cast stainless steel
Handle	.304 stainless steel
Ball & Stem	.316L stainless steel
Actuators	Epoxy coated (standard)
Surface finish	.20 RA ID Stainless Steel (optional)
Actuator bracket, coupling and hardware	.304 stainless steel



5308 Ball Valve

Sizes

- Model 5308 (Tri-Clamp connections):**
½" to 4" (12.7mm to 101.6mm) Tube OD (2 way)
- Model 5309 (Butt-Weld connections):**
½" to 2" (12.7mm to 50.8mm) Tube OD (2 way)

Torque vs. Pressure

Standard Seats

1/2" (12.7 mm) - 2" (50.8 mm) Tube OD

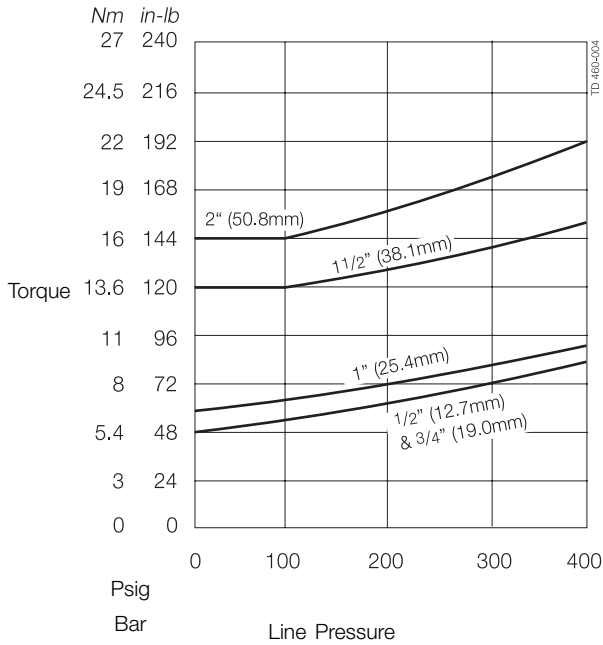

3" (76.2 mm) - 4" (101.68 mm) Tube OD

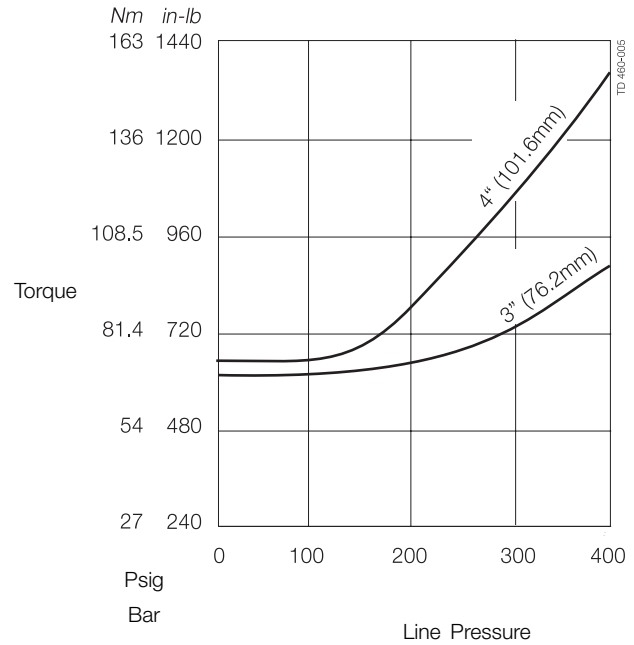

Encapsulated Seats

1/2" (12.7 mm) - 2" (50.8 mm) Tube OD

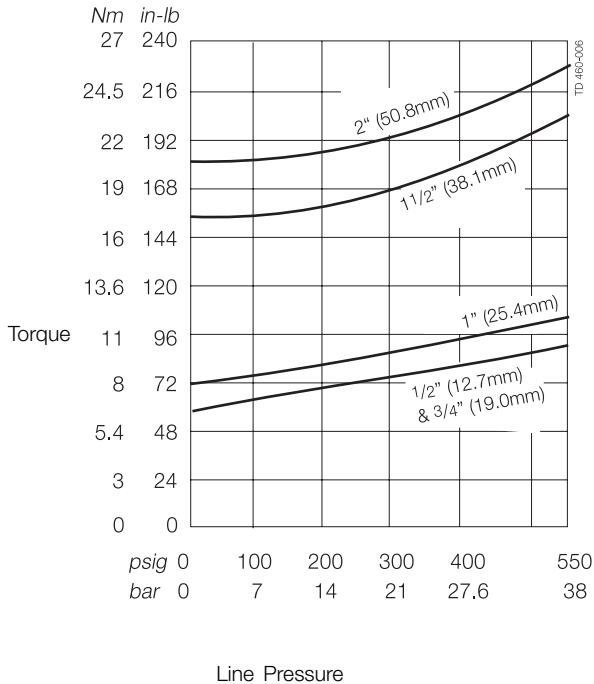

3" (76.2 mm) - 4" (101.68 mm) Tube OD

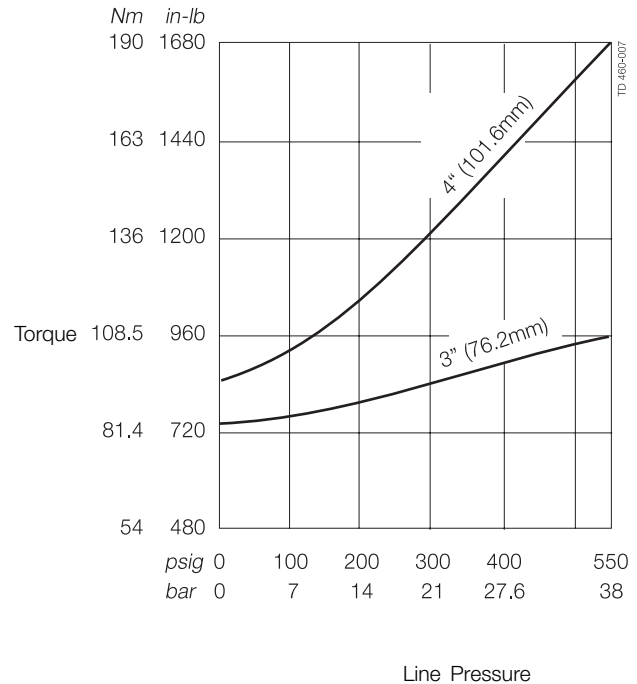

Use the charts above to determine the amount of torque required to cycle the ball valve.

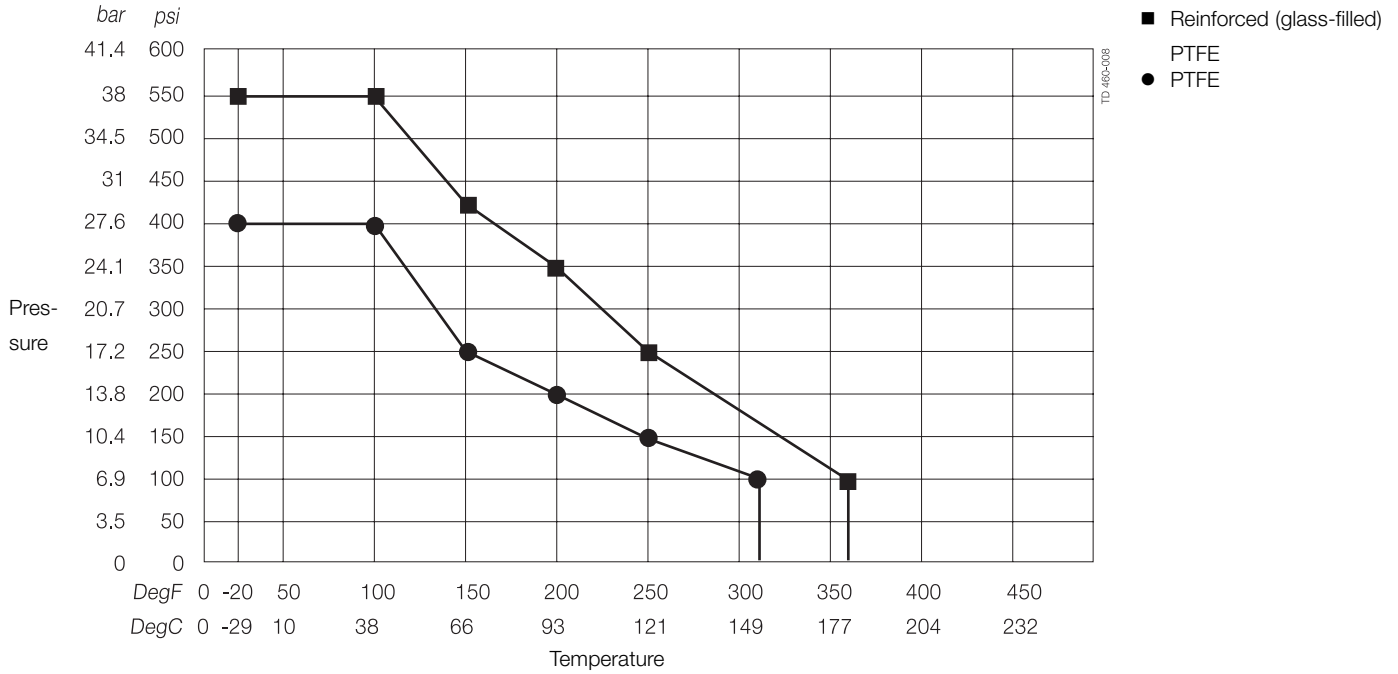

Manual Valve Dimensions

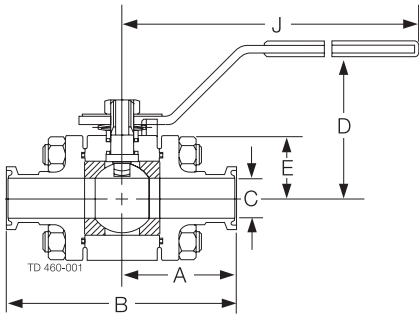

Tri-Clamp® Ends
Model 5308
Sizes 1/2" - 2"

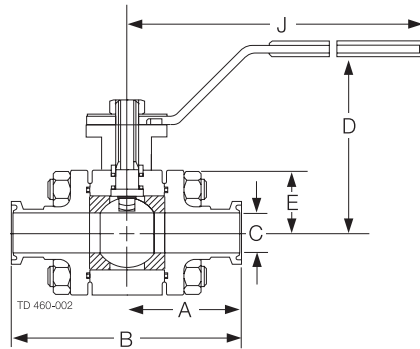

Tri-Clamp® Ends
Model 5308
Sizes 3" and 4"

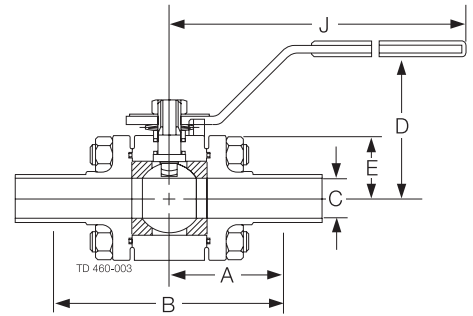

Butt-Weld Ends
Model 5309

Model	Size		A		B		C		D		E		J		Weight (valve + handle)	
	inch	mm	inch	mm	inch	mm	inch	mm	inch	mm	inch	mm	inch	mm	lb	kg
5308 Tri-Clamp® (both ends)	1/2	12.7	1.75	44.5	3.50	88.9	0.37	9.5	2.3	58.7	1.14	29.0	5.25	134	2	0.9
	3/4	19.0	1.75	44.5	3.50	88.9	0.63	15.9	2.4	61.9	1.14	29.0	5.25	134	2	0.9
	1	25.4	1.75	44.5	3.50	88.9	0.84	21.4	2.3	58.7	1.30	33.0	5.25	134	3	1.4
	1 1/2	38.1	2.25	57.2	4.50	114.3	1.36	34.5	3.8	95.3	1.57	40.0	6.69	170	6	2.7
	2	50.8	2.50	63.5	5	127.0	1.86	47.2	4.1	104.8	2.19	55.5	8.15	207	10	4.5
	3	76.2	3.87	98.4	7.75	196.9	2.86	72.6	7	177.8	4.56	115.5	11.75	298.4	30	13.6
5309 Butt-Weld (both ends)	4	101.6	4.75	120.7	9.50	241.3	3.19	81.0	7.5	190.5	5.26	113.5	13.25	336.5	47	21.3
	1/2	12.7	2.69	68.3	5.37	136.5	0.37	9.5	2.3	58.7	1.14	29.0	5.75	134.0	2	0.9
	3/4	19.0	2.81	71.4	5.63	142.9	0.63	15.9	2.4	61.9	1.14	29.0	5.75	134.0	2	0.9
	1	25.4	3.22	81.8	6.44	163.5	0.84	21.4	2.3	58.7	1.30	33.0	5.75	134.0	3	1.4
	1 1/2	38.1	3.63	92.1	7.25	184.2	1.36	34.5	3.8	95.3	1.57	40.0	6.69	170.0	6	2.7
2	50.8	3.19	81.0	7.63	193.7	1.86	47.2	4.1	104.8	2.19	55.5	8.15	207.0	10	4.5	



Valves with Pneumatic Actuators

Alfa Laval offers two types of pneumatic actuators, available in air-to-air or air-to-spring. Air-to-spring is available in normally open or normally-closed models. All models are offered with epoxy-coated aluminium alloy or optional 304 stainless steel housing. Pneumatic actuator air pressure requirements are:

Air-to-Air: 25 to 100 psi (1.7 to 6.9 bar)

Air-to-Spring: 80 to 100 psi (5.5 to 6.9 bar)

Note: Air pressure requirements are dependent upon the valve scope and operating conditions.

Selection Tables for Pneumatic Actuators

Stainless Steel			
Valve Size	Type	Air Volume Req'd	NTP Air Connector Size
½" or ¾"	Air-to-Air	15.26 cu. in.	1/8"
1" or 1½"	Air-to-Air	15.26 cu. in.	1/8"
2"	Air-to-Air	36.60 cu. in.	1/8"
3" or 4"	Air-to-Air	67.12 cu. in.	1/8"
½"	Air-to-Spring	9.15 cu. in.	1/8"
¾", 1" or 1½"	Air-to-Spring	15.26 cu. in.	1/8"
2"	Air-to-Spring	27.46 cu. in.	1/8"
3" or 4"	Air-to-Spring	86.65 cu. in.	1/4"

Aluminum			
Valve Size	Type	Air Volume Req'd	NTP Air Connector Size
½" or ¾"	Air-to-Air	15.26 cu. in.	1/8"
1" or 1½"	Air-to-Air	15.26 cu. in.	1/8"
2"	Air-to-Air	36.60 cu. in.	1/8"
3" or 4"	Air-to-Air	67.12 cu. in.	1/8"
½"	Air-to-Spring	9.15 cu. in.	1/8"
Cv" or 1"	Air-to-Spring	9.15 cu. in.	1/8"
1Zx"	Air-to-Spring	15.26 cu. in.	1/8"
2"	Air-to-Spring	22.00 cu. in.	Z,"
3" or 4"	Air-to-Spring	86.65 cu. in.	Zv"

Dimensions - Accord Switch Options

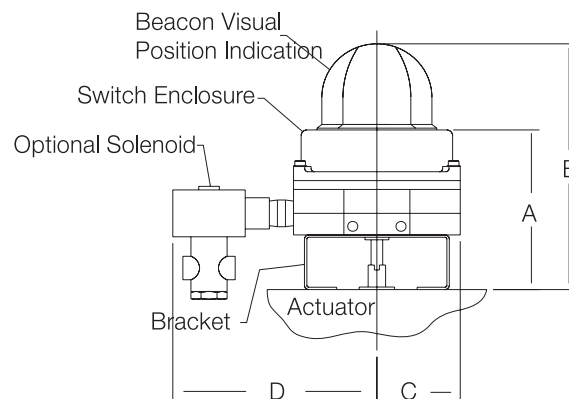

Model	A		B		C		D	
	inch	mm	inch	mm	inch	mm	inch	mm
NEMA 4, 4X, 7, 9 (Aluminum)	5.13	130.2	7.59	192.9	2.63	66.7	6.06	154.0
NEMA 4, 4X (Zytel)	5.13	130.2	7.59	192.9	2.31	58.7	4.06	103.2

Optional: Two mechanical or proximity switches contained within the enclosure.

Pneumatic Actuator Options

- A. All stainless steel and non-stainless, epoxy coated aluminum alloy actuators can be furnished with a basic switch enclosure. Specify either NEMA 4 or NEMA 7. The enclosure/bracket assembly is mounted on top of the actuator.
- B. Basic switch enclosure can be furnished with optional Pharos visual indicator.

- C. 3-way and 4-way solenoids can be mounted to basic switch enclosure. All wire connections are through a terminal strip, located inside the basic switch enclosure.

Dimensions - Valves with Pneumatic Actuators
Tri-Clamp® Connection

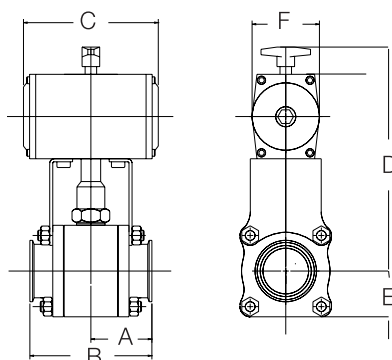

Air to Air Actuators (Aluminum or Stainless Steel)															
Model	Size		A		B		C		D		E		F		
	inch	mm	inch	mm	inch	mm	inch	mm	inch	mm	inch	mm	inch	mm	
5308 Tri-Clamp® ends	½	12.7	1.75	44.5	3.50	88.9	4.25	107.9	5.62	142.8	0.91	23.0	3.00	76.0	
	¾	19.0	1.75	44.5	3.50	88.9	4.25	107.9	5.69	144.4	0.97	24.6	3.00	76.0	
	1	25.4	1.75	44.5	3.50	88.9	4.25	107.9	5.78	146.0	1.13	28.6	3.00	76.0	
	1½	38.1	2.25	57.2	4.50	114.3	4.25	107.9	6.661	168.0	1.50	38.1	3.00	76.0	
	2	50.8	2.50	63.5	5.00	127.0	5.24	133.0	8	203.0	1.87	47.6	2.75	69.8	
	3	76.2	3.87	98.4	7.75	196.9	8.03	204.0	10.87	276.0	2.72	69.1	3.96	100.7	
4	101.6	4.75	120.7	9.50	241.3	8.03	204.0	11.56	293.7	3.47	88.1	3.96	100.7		

Air to Spring Actuators (Aluminum)															
Model	Size		A		B		C		D		E		F		
	inch	mm	inch	mm	inch	mm	inch	mm	inch	mm	inch	mm	inch	mm	
5308 Tri-Clamp® ends	½	12.7	1.75	44.5	3.50	88.9	4.25	107.9	5.62	142.8	0.91	23.0	3.00	76.0	
	¾	19.0	1.75	44.5	3.50	88.9	7.00	177.8	6.50	165.0	0.97	24.6	3.62	92.0	
	1	25.4	1.75	44.5	3.50	88.9	7.00	177.8	7.75	196.8	1.13	28.6	3.62	92.0	
	1½	38.1	2.25	57.2	4.50	114.3	8.03	204.0	8.37	212.7	1.50	38.1	3.62	92.0	
	2	50.8	2.50	63.5	5.00	127.0	8.03	204.0	8.81	223.8	1.87	47.6	3.96	100.7	
	3	76.2	3.87	98.4	7.75	196.9	11.50	292.0	13.03	331.0	2.72	69.1	5.37	136.5	
4	101.6	4.75	120.7	9.50	241.3	11.50	292.0	13.74	349.0	3.47	88.1	5.37	136.5		

Air to Spring Actuators (Stainless Steel)															
Model	Size		A		B		C		D		E		F		
	inch	mm	inch	mm	inch	mm	inch	mm	inch	mm	inch	mm	inch	mm	
5308 Tri-Clamp® ends	½	12.7	1.75	44.5	3.50	88.9	4.25	107.9	5.62	142.8	0.91	23.0	3.00	76.0	
	¾	19.0	1.75	44.5	3.50	88.9	7.00	177.8	7.75	196.8	0.97	24.6	3.62	92.0	
	1	25.4	1.75	44.5	3.50	88.9	7.00	177.8	7.75	196.8	1.13	28.6	3.62	92.0	
	1½	38.1	2.25	57.2	4.50	114.3	7.00	177.8	8.38	212.7	1.50	38.1	3.62	92.0	
	2	50.8	2.50	63.5	5.00	127.0	8.03	204.0	9.13	231.8	1.87	47.6	3.96	100.7	
	3	76.2	3.87	98.4	7.75	196.9	11.50	292.0	13.03	331.0	2.72	69.1	5.37	136.5	
4	101.6	4.75	120.7	9.50	241.3	11.50	292.0	13.74	349.0	3.47	88.1	5.37	136.5		

Note: 3" and 4" valves do not require actuator mounting brackets. Body Design includes actuator mounting pad as standard.



Dimensions - Valves with Pneumatic Actuators Butt-Weld Connection

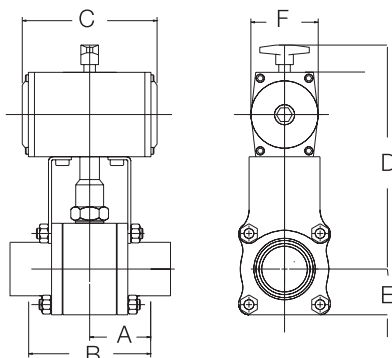

Air to Air Actuators (Aluminum or Stainless Steel)														
Model	Size		A		B		C		D		E		F	
	inch	mm	inch	mm	inch	mm	inch	mm	inch	mm	inch	mm	inch	mm
5309	½	12.7	2.69	68.3	5.37	136.5	4.25	107.9	5.62	142.8	0.91	23.0	3.00	76.0
	¾	19.0	2.81	71.4	5.63	142.9	7.00	177.8	5.69	144.4	0.97	24.6	3.00	76.0
Weld ends	1	25.4	3.22	81.8	6.44	163.5	7.00	177.8	5.75	146.0	1.13	28.6	3.00	76.0
	1½	38.1	3.63	92.1	7.25	184.2	7.00	177.8	6.61	168.0	1.50	38.1	3.00	76.0
	2	50.8	3.94	100.0	7.63	193.7	8.03	204.0	8.00	203.0	1.87	47.6	2.75	69.8

Air to Spring Actuators (Aluminum)														
Model	Size		A		B		C		D		E		F	
	inch	mm	inch	mm	inch	mm	inch	mm	inch	mm	inch	mm	inch	mm
5309	½	12.7	2.69	68.3	5.37	136.5	4.25	107.9	5.62	142.8	0.91	23.0	3.00	76.0
	¾	19.0	2.81	71.4	5.63	142.9	5.24	133.0	6.50	165.0	0.97	24.6	2.75	69.8
Weld ends	1	25.4	3.22	81.8	6.44	163.5	5.24	133.0	7.75	196.8	1.13	28.6	2.75	69.8
	1½	38.1	3.63	92.1	7.25	184.2	7.00	177.8	8.37	212.7	1.50	38.1	3.62	92.0
	2	50.8	3.94	100.0	7.63	193.7	7.00	177.8	8.81	223.8	1.87	47.6	3.62	92.0

Air to Spring Actuators (Stainless Steel)														
Model	Size		A		B		C		D		E		F	
	inch	mm	inch	mm	inch	mm	inch	mm	inch	mm	inch	mm	inch	mm
5309	½	12.7	2.69	68.3	5.37	136.5	4.25	107.9	5.62	142.8	0.91	23.0	3.00	76.0
	¾	19.0	2.81	71.4	5.63	142.9	7.00	177.8	7.75	196.8	0.97	24.6	3.62	92.0
Weld ends	1	25.4	3.22	81.8	6.44	163.5	7.00	177.8	7.75	196.8	1.13	28.6	3.62	92.0
	1½	38.1	3.63	92.1	7.25	184.2	7.00	177.8	8.37	212.7	1.50	38.1	3.62	92.0
	2	50.8	3.94	100.0	7.63	193.7	8.03	204.0	9.13	231.8	1.87	47.6	3.96	100.7

Options Equipment

- Product connections: weld, bevel seat
- Position indication: mechanical or proximity switches

Ordering

Please state the following when ordering:

- Size.
- Product connections
- Valve body combination.
- Actuator function, NC, NO or A/A
- Options.

