

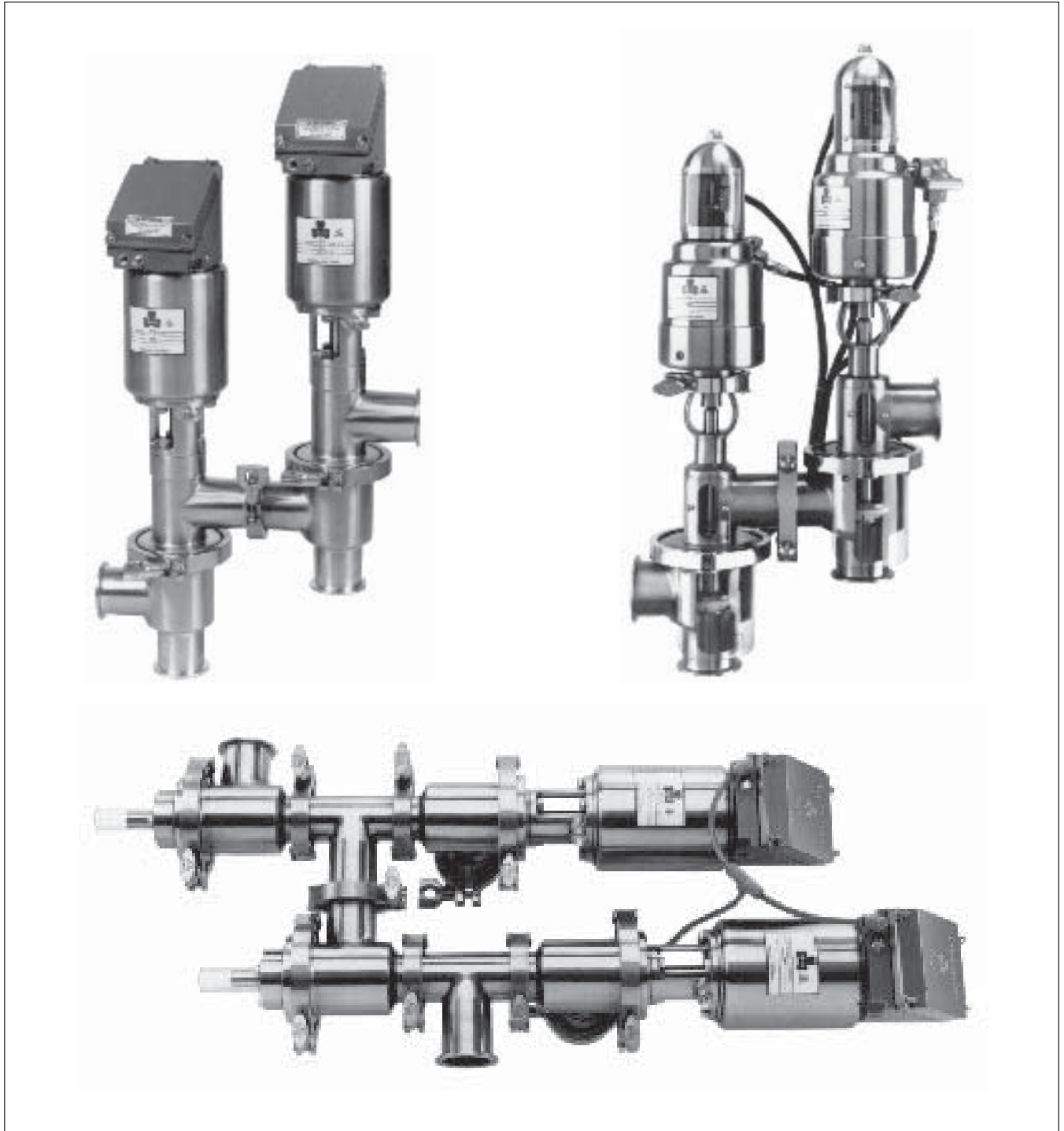

# TRI-CLOVER® Flo-Diversion Valves



The United States Public Health Service and other regulatory groups, while being aware of increased demands on processors, continue to insist on maintaining the high standards for the Dairy Industry's products and processes.

One of the processes under constant surveillance is the High Temperature Short Time (HTST) system. Tri-Clover's air actuated Flo-Diversion Valve Units assist in monitoring the performance of the HTST system. This assures the processor of high product quality by maintaining high standards. Availability in sizes 1½ (not available in 762-227 MRAL), 2, 2½, and 3 inches offers to the processors the advantage of selecting a valve that will handle any HTST flow requirement for units now in existence.

## Benchmark in Quality

- The design of the Flo-Diversion Valve offers the distinct advantage of cleanability-in-place, eliminating the need to dismantle the valve during the cleaning operations of the HTST and holding tube.
- The control system for the Flo-Diversion Valve is designed to work in conjunction with present existing safety Thermo/Limit Controllers designed for HTST applications.
- Pneumatic or electric power failure automatically places the valve into a divert position diverting unsafe product into the balance tank. Electric failure of the control system will automatically stop the timing pump.
- Valve control system will automatically flush leak detector port prior to going into forward flow.
- All metal parts coming in contact with the product are manufactured from Type 316 stainless steel on the 262 model and Type 316L stainless steel on the 762 models. The inert, synthetic rubber compound material, used for the spherical valve plug seats, is odorless, tasteless and unaffected by cleaning solutions.
- Actuator assemblies can be assembled or disassembled with ease. No special tools are required for actuator servicing.
- Tri-Clover's Flo-Diversion Valves have been designed to meet all requirements of the PMO and 3A.
- Automated dairies demand valves that function at peak performance without sacrificing the safety factor ... Tri-Clover's Flo-Diversion Valve meets this challenge.
- Microswitch control housings on the 762 Series meet NEMA 4 specifications.
- "Fail Safe" operation is assured, as the valve microswitches act as a safety device to the entire Flo-Diversion system. Valve microswitches are factory adjusted so that the timing pump will not run at sublethal pasteurization temperatures.

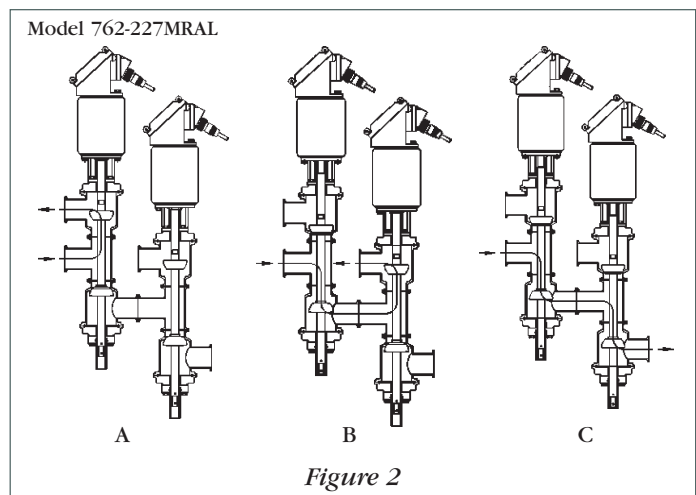
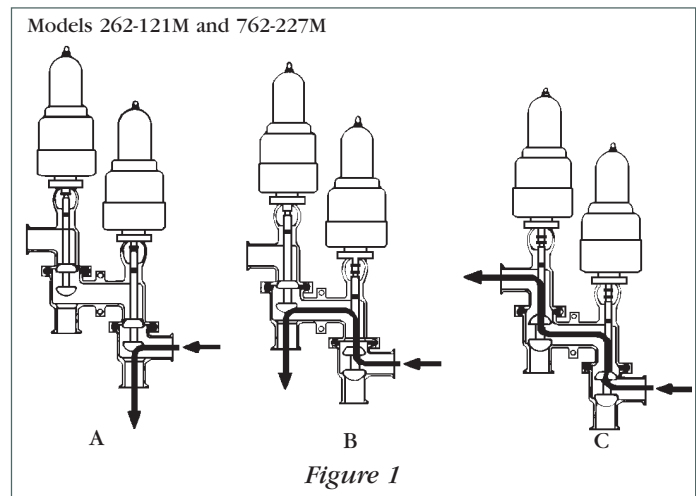

The valves, which can be cleaned-in-place, are designed and engineered to respond positively and accurately to controls for HTST operations. The control panel for the Flo-Diversion Valve is uncomplicated — no complex or intricate circuitry. It will, however, work in conjunction with the most sophisticated HTST instrument control systems.

## Principles of Operation

### Product Flow

To assume forward flow turn the "Inspect-Product-Clean" switch on the Control Panels to "Product". The valve plug assembly of the divert valve section will remain in its normal divert position diverting product into the balance tank until safe pasteurization temperatures are reached and maintained. (See Figure 1A and 2A). At this time the temperature limit switch (part of the HTST Instrument Control) is activated. The circuit to the solenoid for the divert valve section is closed actuating the divert valve. The divert valve plug assembly will then close off the divert port. The product will flow through the leak detector port for a predetermined period of time. (See Figure 1B and 2B). This will flush the divert and leak detector sections of the valve prior to going into forward flow.

At the end of the predetermined period the circuit to the solenoid for the leak detector valve section is closed actuating the leak detector valve. The leak detector valve plug assembly

# Flo-Diversion Valve Model 262-121M

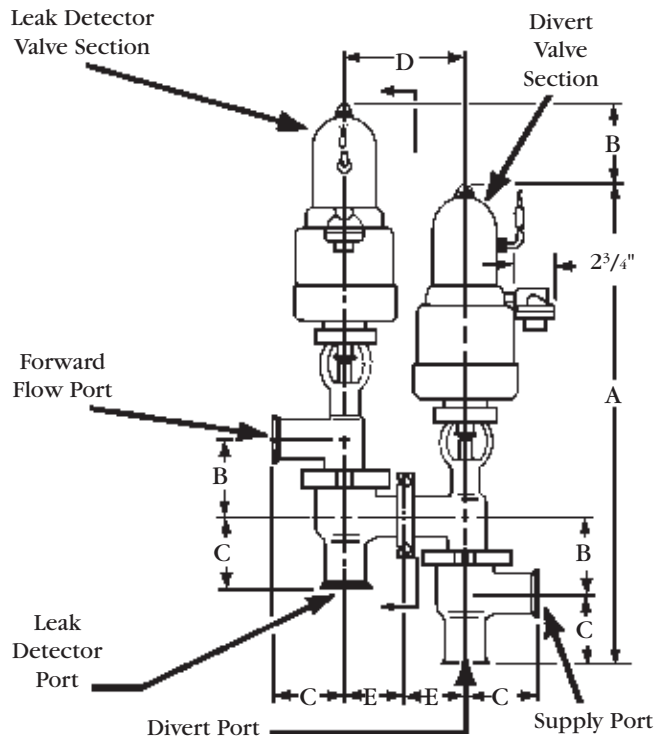

Valve Model / Size	Maximum Operating Pressure (PSI)	Maximum Capacity (GPM)	Air Supply Pressure Required
262-121-1 1/2"	100	60	50
262-121-2"	100	95	50
262-121-2 1/2"	100	175	50
262-121-3"	50	215	50
262-121-3H	100	215	80

Valve Size	1 1/2	2	2 1/2	3
A	23	24 1/4	25	26
B	3 1/4	3 3/4	4 1/4	4 3/4
C	2 3/4	3 1/2	3 1/2	3 3/4
D	6	6	7 1/16	7 9/16
E	3	3	3 17/32	3 25/32
Valve Weight Lbs.	38	45	52	59

then closes the leak detector port. The product has now assumed full forward flow. (See Figure 1C and 2C). The microswitches located on the valve actuators will now be activated, causing the green indicating light, showing forward flow, to light up.

When safe pasteurization temperatures have not been reached or maintained, the temperature limit switch will resume or stay in its normal position, opening the circuits to the solenoid valves, causing them to return the divert valve and leak detector valve to their normal positions, diverting the product into the balance tank. When the Flo-Diversion Valve returns to the divert position the microswitches will open the circuit to the green indicating light and complete the circuit to the red indicating light, showing diverted flow.

The divert flow sequence just described was automatic. To manually divert forward product flow into the balance tank push the "Manual Diversion" button on the Control Panel.

### Cleaning-In-Place

To clean the valve in place turn the "Inspect-Product-Clean" switch on the Control Panel to the "Clean" position. The cam timer is activated. Panels include a 10 minute timer to delay valve actuators which will position the valve plug assemblies in divert flow, leak detector flow and forward flow. (See Figures 1 and 2 for flow patterns).

Cleaning solution flowing through valve will clean the valve in all these positions. A spare contact on the "Clean" position of the switch is wired to the terminal strip which can be used to run the Timing pump during CIP if desired.

### Inspect

The Tri-Clover Flo-Diversion Valve can be dismantled without immersing the temperature bulb. When the "Inspect-Product-Clean" switch is placed in the "Inspect" position the valve assumes a forward flow position, necessary for inspection takedown. The "Inspect" position of the switch is wired to disable the Timing pump from running. This prevents unsafe product being forwarded when the valve is in the Inspect position.

## 762-227 Flo-Diversion Valve

Tri-Clover's new product line extends from our popular Tri-Flo® 761 Series and incorporates the same user-friendly benefits:

- Designed in compliance with current sanitary/regulatory standards.
- All wetted parts are type 316L SS, polished ID/OD.
- Quick connect Tri-Clamp® ports for ease of assembly.

# Flo-Diversion Valve Model 762-227M

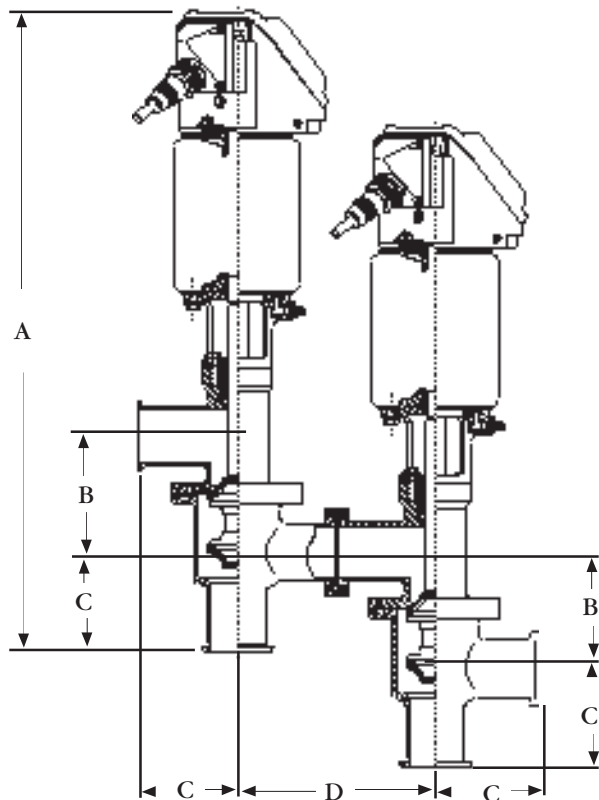

- Available in 1½", 2", 2½" or 3" tube O.D. sizes.
- Low maintenance, permanently assembled actuators provide years of worry-free service.
- Valve stem threads onto actuator stem, providing improved stem alignment — no coupler required.
- Choice of molded elastomer seat materials, or other popular, low cost "TR" replaceable seal/seat assembly.

Like our Series 761 valves, a NEMA 4 microswitch control housing, mounted on the valve actuator, allows for installation of solenoids on the valve itself, not in the remote control panel. This eliminates the need for the quick air exhaust, required in previous Flo-Diversion Valve designs. Or, you have the option of locating the solenoids in the control panel.

## 762-227 MRAL Reverse-Acting Valve

Unlike old style Flo-Diversion Valve assemblies, our new 762 RA valves feature a two piece stem held securely together with a stainless steel nut outside the product stream. This patented revolutionary stem design allows valves to close against product flow eliminating hydraulic shock.

These valves are installed in your process line HORIZONTALLY rather than vertically. Complete valve

drainage is assured as tangential bodies are used. The "divert" valve is positioned higher than the "leak detect" valve in the complete assembly. Use of right-hand and left-hand tangential bodies provides maximum installation versatility as the valve actuator can be mounted on either end of the valve to accommodate various process line configurations.

## Model Numbers for Valves and Panels

Each air actuated valve and panel is identified by a model number. An interpretation of how this coding system is used to specify various components is shown below.

The 262 style is only available with the solenoid mounted in the panel. The Flo-Diversion Valve (FDV) normally does not have a solenoid mounted on the valve.

262-121-"X"-SIZE-316  
(262 style, includes valve and panel)

"X" indicates the type of panel supplied with valve.

{	"C"	110 VAC with 10 minute timer #48-2120-E-115
{	"D"	220 VAC with 10 minute timer #48-2120-E-220
{	" "	Valve only, no panel supplied

On the 762 series the valve and panel are separate items.

Valve Model / Size	Maximum Operating Pressure (PSI)	Maximum Capacity (GPM)	Air Supply Pressure Required
762-227-1½"	100	60	80
762-227-2"	100	95	80
762-227-2½"	100	175	90
762-227-3"	50	215	90
762-227-3H	100	215	95

Valve Size	1½	2	2½	3
A	22¼	22¾	23¾	24¾
B	4⅝	4⅞	4½	5
C	2¾	3½	3½	3¾
D	5⅑/16	7⅑/16	7⅑/16	7⅑/16
Stroke	15/16	15/16	15/16	15/16

# Flo-Diversion Valve Model 762-227MRAL

U.S. Patent 5,152,320



**CSI**

417.831.1411  
csidesigns.com

Valve Model / Size	Maximum Operating Pressure (PSI)	Maximum Capacity (GPM)	Air Supply Pressure Required
762-227MRAL-2"	155	100	80
762-227MRAL-2 1/2"	50	175	90
762-227MRAL-3"	35	225	95

If higher holding pressures are required contact Tri-Clover.

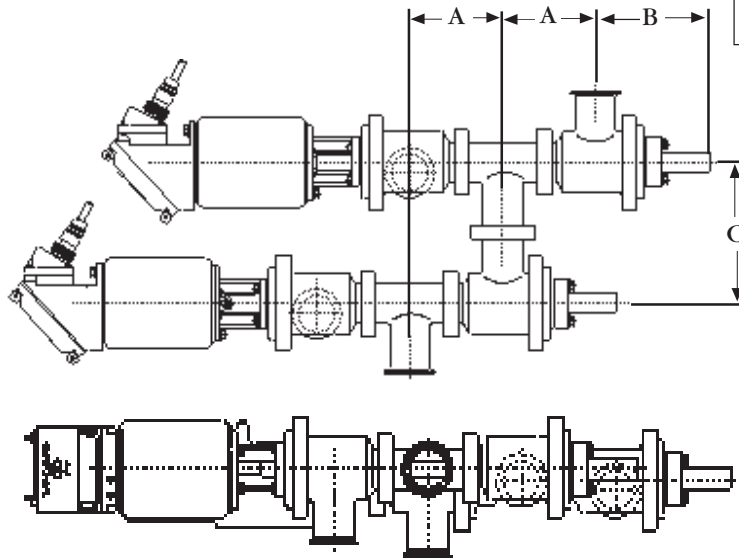

Valve Size	2	2 1/2	3
A	4 <sup>23</sup> / <sub>32</sub>	5 <sup>1</sup> / <sub>4</sub>	5 <sup>3</sup> / <sub>4</sub>
B	5 <sup>51</sup> / <sub>64</sub>	6 <sup>1</sup> / <sub>32</sub>	6 <sup>9</sup> / <sub>32</sub>
C	7 <sup>1</sup> / <sub>16</sub>	7 <sup>1</sup> / <sub>16</sub>	7 <sup>9</sup> / <sub>16</sub>
D	3 <sup>1</sup> / <sub>2</sub>	3 <sup>1</sup> / <sub>2</sub>	3 <sup>3</sup> / <sub>4</sub>
E	.513	.814	.814

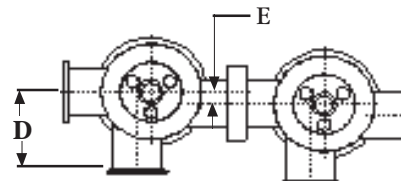

Both components must be specified for a complete FDV assembly.

762-227M-SIZE-316L-1-"Y"  
(761 style, normal valve only)

762-227MRAL-SIZE-316L-1-"Y"  
(reverse acting valve only)

"Y" indicates the type of solenoid supplied with valve.

- "1" 110 VAC solenoid #33-169
- "2" 24 VAC solenoid #33-170\*
- "3" 24 VDC solenoid #33-171
- "4" No solenoid (supplied in panel)

\*24 VAC is the standard voltage required by any FDV using a #48-2762-1 or #48-2762-2 panel.

## Control Panels

Models #48-2762-1 and #48-2762-2

Model #48-2762-1 uses an Allen Bradley Model SLC 500 controller. No solenoids are supplied in the panel. The solenoids normally are mounted in the valve control top module. Model #48-2762-2 also uses an Allen Bradley Model SLC 500 Controller. Two solenoids (one per valve), 115 VAC, are provided inside the panel.

115VAC supply voltage is required to the panels. The valve

top solenoids and switches are operated at 24VAC (for safety reasons ) from the panel.

Stainless Steel Enclosure, NEMA 12, 18"H x 14"W x 8"D. Both have provisions for regulatory seals.

Models #48-2120-E-115 and #48-2120-E-220

Panels 48-2120-E-115 and 48-2120-E-220 are intended to be used with the 262 Series Valve.

Electro-Mechanical Relay control panel Model #48-2120-E-115 is available for use with the 762 Series Valve only if 110 VAC solenoids are used. The panel supplies two 115 VAC solenoids (one per valve) and the required 10 minute CIP time delay. (24 volt or 220 VAC solenoids are not available in this case)

Valve switches are operated at 115 or 220VAC. *Use caution when operating and servicing at these voltages.*

Stainless Steel Enclosure, NEMA 12, 16"H x 14"W x 8"D. Models have provisions for regulatory seals.

**TERMS, WARRANTY PROVISIONS,  
NOTICE OF CLAIMS AND  
LIMITATION OF LIABILITY**

Prices and all terms and conditions of sale are established in current price sheets and are subject to change without notice. All orders are subject to acceptance by Tri-Clover Inc. at its Kenosha, Wisconsin or Distribution Center\* offices only. No assignment of the purchaser's rights may be made without consent of Tri-Clover Inc.

Each Tri-Clover item is warranted to be free from manufacturing defects for a period of one (1) year from the date of shipment, providing it has been used as recommended and in accordance with recognized piping practice, and providing it has not been worn out due to severe service, such as encountered under extremely corrosive or abrasive conditions.

**THIS WARRANTY IS EXPRESSLY IN LIEU OF ANY OTHER WARRANTIES, EXPRESS OR IMPLIED, INCLUDING BUT NOT LIMITED TO, ANY IMPLIED WARRANTY OF MERCHANTABILITY OR FITNESS FOR A PARTICULAR PURPOSE.**

All claims must be in writing and must be mailed or delivered by purchaser within thirty (30) days after purchaser learns of the facts upon which such claim is based. Any claim not made in writing and within the time period specified above shall be deemed waived.

**PURCHASER'S SOLE AND EXCLUSIVE REMEDY AND TRI-CLOVER INC.'S MAXIMUM LIABILITY FOR CLAIMS ARISING HEREUNDER OR FOR NEGLIGENCE FOR ANY AND ALL LOSSES AND DAMAGES RESULTING FROM ANY CAUSE SHALL BE EITHER THE REPAIR OR REPLACEMENT OF DEFECTIVE ITEMS OR, AT TRI-CLOVER INC.'S OPTION, THE REFUND OF THE PURCHASE PRICE FOR SUCH ITEMS. IN NO EVENT, INCLUDING IN THE CASE OF A CLAIM FOR NEGLIGENCE, SHALL TRI-CLOVER BE LIABLE FOR INCIDENTAL OR CONSEQUENTIAL DAMAGES INCLUDING LOSS OF PROFITS.**

No person, including any representative, employee or agent of Tri-Clover, is authorized to assume on behalf of Tri-Clover Inc., any liability or responsibility in addition to or different from that described in this provision. Any and all representations, promises, warranties or statements that are in addition to or different from the terms of this provision are of no force or effect.

*\*Distribution Centers in Union City, California and Memphis, Tennessee*

In addition to manufacturing the most complete line of stainless steel flow control products and components, Tri-Clover provides the most complete, up-to-date and comprehensive literature to assist you in ordering and specifying them:

Following are all registered trademarks of Tri-Clover Inc.

- |            |             |
|------------|-------------|
| Tri-Clover | Tri-Blender |
| Tri-Clamp  | Tri-Flo     |
| Tri-Weld   | Super-Speed |
| Zephyrweld | Tri-Taper   |
| Mainstream | Streamline  |



**Tri-Clover Inc.**

9201 Wilmot Road  
Kenosha, Wisconsin 53141-1413  
414-694-5511  
FAX: 414-694-7104  
International Sales: 414-697-3170  
FAX: 414-694-8188

Tri-Clover Canada  
101 Milner Avenue  
Scarborough, Ontario M1S 4S6  
416-299-5490  
FAX: 416-299-5095

Tri-Clover Mexico  
Recursos Petroleros No. 7  
Fracc. Ind. La Loma  
54060 Tlalnepantla, Edo. de Mexico  
PHONE: 52-5-397-0601 FAX: 52-5-362-3246

