

CL Pump Configuration Worksheet

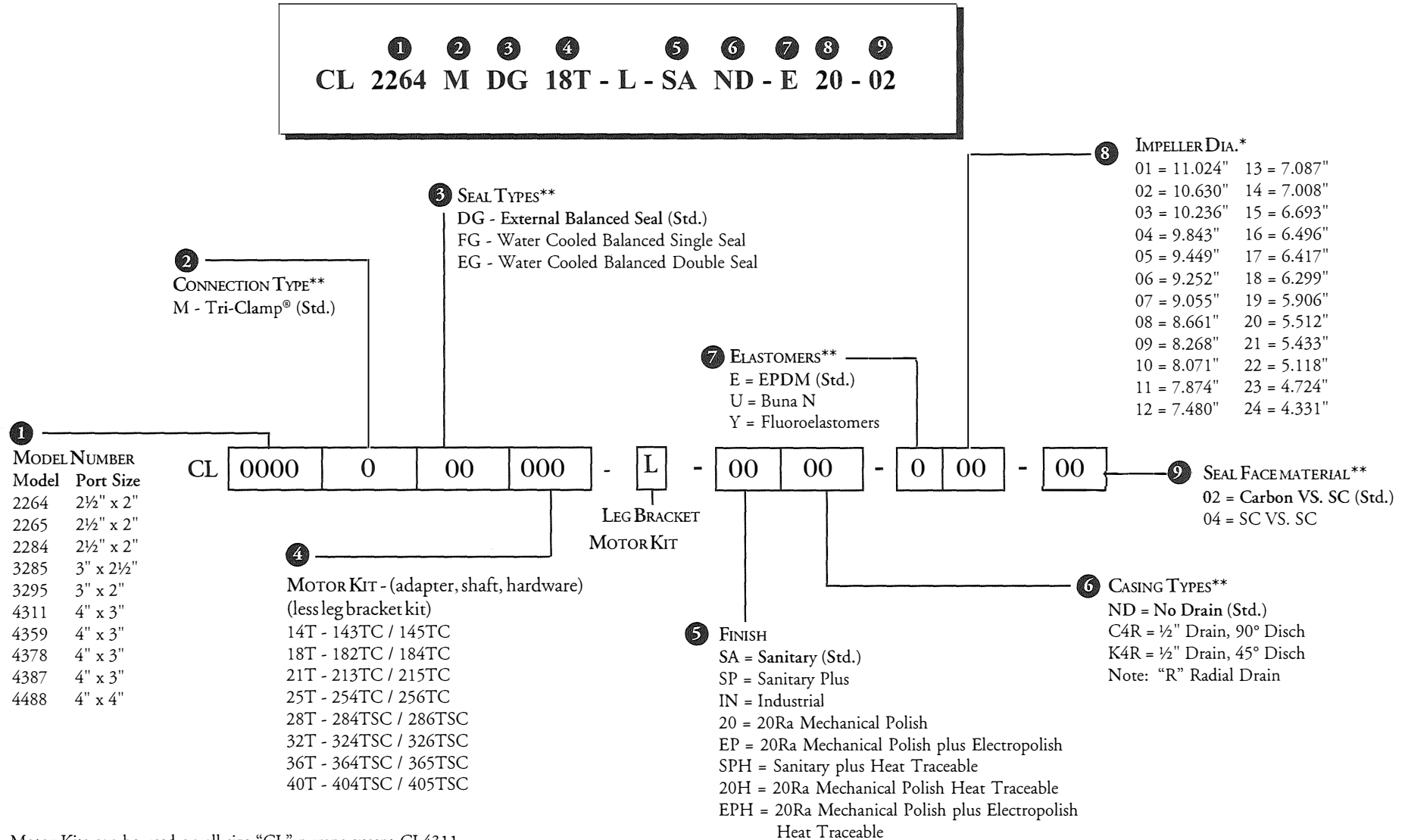

Consider the information below when selecting a CL pump.

Note: The configuration shown below will not reflect the actual model number shown on the Customer Order Acknowledgement.



Notes: 1. Motor Kits can be used on all size "CL" pumps except CL4311.

CL4311 adapter does not interchange.

examples: CL-21TC (for all "CL" pumps except CL4311)

CL4311-21TC (for CL4311 pump only)

* Refer to tables for impeller sizes available per model types.

** Other options available upon request.

CLW Pump Configuration Worksheet

Consider the information below when selecting a CL pump.

Note: The configuration shown below will not reflect the actual model number shown on the Customer Order Acknowledgement.

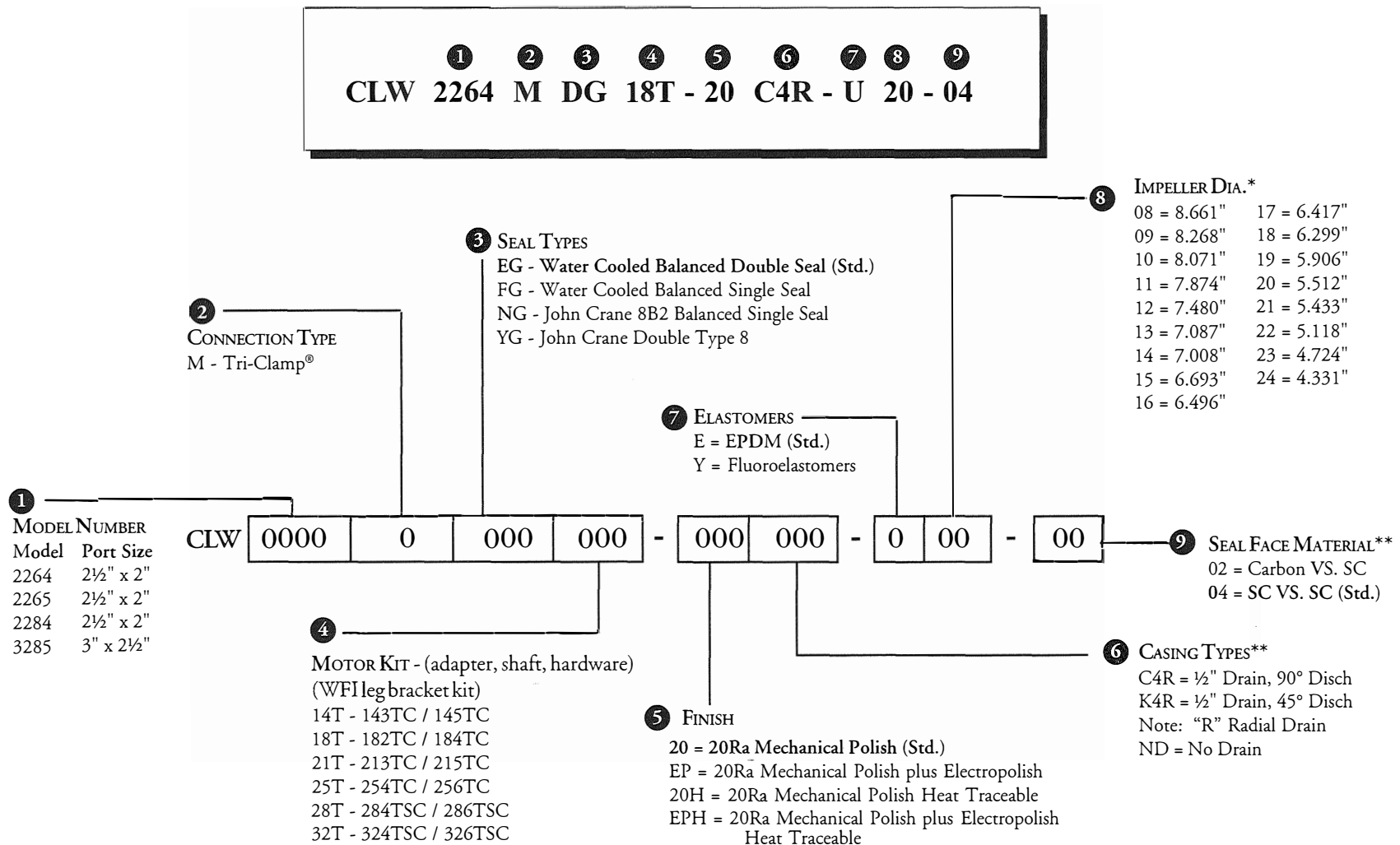

Notes: 1. Motor Kits can be used on all size "CLW" pumps except CLW4311.

CLW4311 adapter does not interchange.

examples: CLW-21TC (for all "CL" pumps except CLW4311)

CLW4311-21TC (for CLW4311 pump only)

* Refer to tables for impeller sizes available per model types.

** Other options available upon request.

CL/CLW Series Table

Impeller Sizes

CL/CLW Series - Impeller Sizes Per Model Type											
Order Code	Impeller Diameter (in.)	Model Number									
		2264	2265	2284	3285	3295	4311	4359	4378	4387	4488
01	11.024						•				
02	10.630						•				
03	10.236						•				
04	9.843						•				
05	9.449						•				
06	9.252					•					
07	9.055					•	•				
08	8.661			•		•	•				
09	8.268			•		•	•				•
10	8.071				•					•	
11	7.874			•	•	•	•			•	•
12	7.480			•	•	•				•	•
13	7.087			•	•	•				•	•
14	7.008								•		
15	6.693			•	•	•			•	•	•
16	6.496		•								
17	6.417	•									
18	6.299	•	•		•				•	•	•
19	5.906	•	•						•	•	
20	5.512	•	•						•		
21	5.433	•							•		
22	5.118	•	•						•		
23	4.724	•	•						•		
24	4.331	•									