

# COMPACT CIP

## A MOBILE & COST-EFFECTIVE SOLUTION FOR YOUR REPEATABLE CLEAN-IN-PLACE NEEDS

Compact CIP was designed with mobility and versatility in mind. The intuitive touchscreen with five built-in wash cycles connects with the PLC to control pump speed, chemical concentration, and temperatures to ensure consistent results. By automating the routine of cleaning with Compact CIP, a plant can have faster cleaning time, shorter downtime, and higher repeatability due to process parameters.

### STANDARD FEATURES & BENEFITS

- Automated cleaning enables the operator to see and record compliance with standards and eliminate process inconsistencies
- Process parameters minimize overuse of chemicals, water, and other resources
- Monitoring of tank level, flow rate, and chemical concentration with data recording up to 8 hours
- User-friendly touchscreen allows operator to monitor washes, view alarms, and see cycle trends (See Fig. 1)
- Flow controlled via VFD (Variable Frequency Drive) supplying power to the centrifugal pump
- Washdown rated motor and instruments
- Corrosion resistant 316L stainless steel wetted material

### SIMPLE INTUITIVE OPERATION

- Uniform graphics simplify operator training and day-to-day operations
- Easy configuration for cycle changes and wash parameters

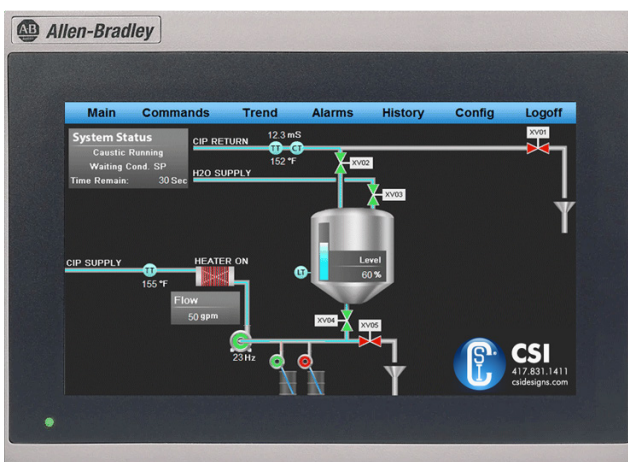

FIG. 1 – HUMAN MACHINE INTERFACE (HMI) HAS USER-FRIENDLY TOUCHSCREEN



# COMPACT CIP

## SPECIFICATIONS

- 100-Gallon tank  
Material 12GA 316L #4 ID/2B OD  
Welds buffed smooth to a 2B ID/OD
- Sanitary centrifugal pump to supply 50gpm @ 50psig
- Mag flowmeter with local display
- Sanitary pressure gauge on discharge of pump
- Sanitary temperature transmitter
- Conductivity transmitter on return line
- Sanitary level transmitter for tank level control
- Alfa Laval premium sanitary butterfly valves
- 304 SS frame
- Automated valves
- Large casters with small footprint for mobility

## OPTIONS

- 30 kW electric heater
- Automated caustic and acid addition
- Chemical reservoirs
- Data recording
- Ethernet connected
- Fixed mounting for extra support
- Adjustable feet for leveling

## APPLICATIONS

- Breweries, Food, Dairy, Beverage, Home Personal Care, and Pet Food industries
- Single-line circuits, individual process tanks, fillers, batching stations, and more

## STANDARD DESIGN

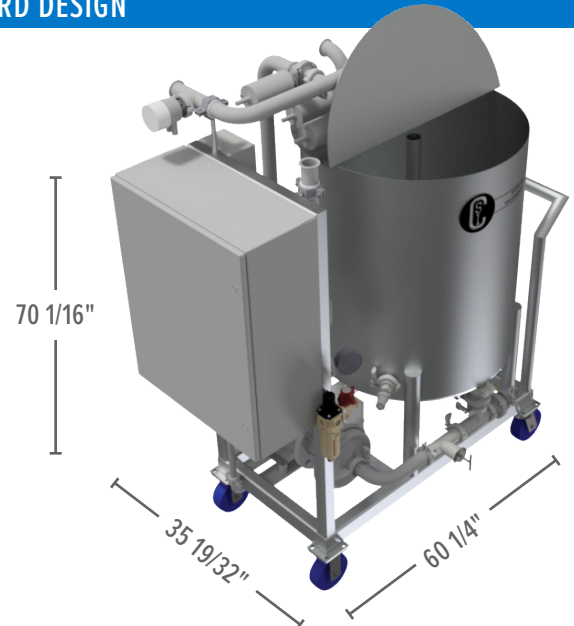

## OPTIONAL DESIGN

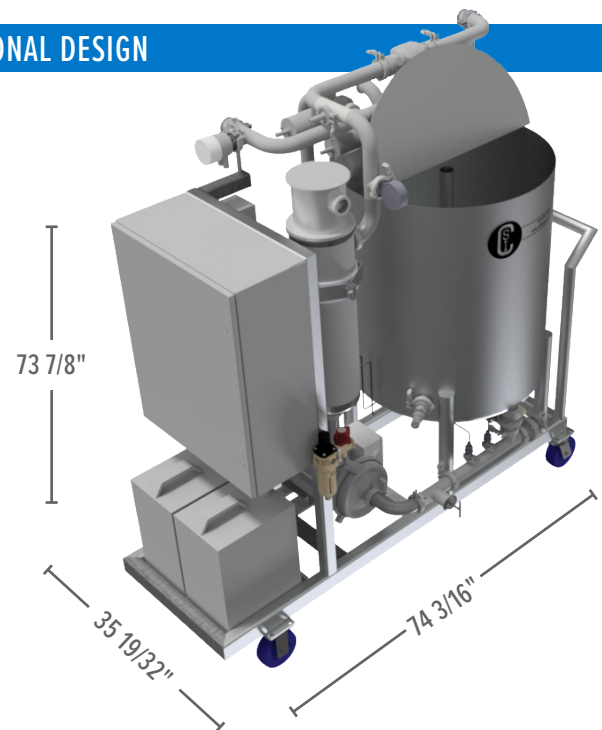

CSIDESIGNS.COM | +1.417.831.1411 | SALES@CSIDESIGNS.COM  
SPRINGFIELD, MO | GRAND PRAIRIE, TX | DURHAM, NC | FRESNO, CA

