



Pure-Flo[®] Advantage 2.1 Actuator



ITT

ENGINEERED FOR LIFE

Advantage[®] 2.1 Actuator / Design

The Next Evolution in Actuation Performance

The Advantage[®] 2.1 actuator is the latest evolution in performance of the time-tested Advantage actuator series, the mainstay of the bioprocessing industry for the past 20 years. The Advantage 2.1 improves the Advantage 2.0 model through an innovative patent pending compressor attachment method that allows for interchangeability between PTFE and elastomer diaphragms without actuator disassembly.



Modular Design

Advantage 2.1 features a modular compressor design for quick changeover between PTFE and elastomer diaphragms. No actuator disassembly is required for diaphragm type changes. The modular design is compatible with all Pure-Flo[®] diaphragm types.

The modular compressor design features a stainless steel compressor and tube. The key to the modular system is a robust stainless steel tube nut that allows compressor float, ensuring even distribution of actuation closing forces. This concept minimizes diaphragm point loading. Diaphragm change over kits will be available.

Note: Design change does not apply to Bio-Tek.

Advantage[®] 2.1 Actuator

Type: Diaphragm Actuator

Size Range: 0.5–2 inches (DN15–DN50)

Operating Modes: Fail close, fail open, double acting

Max Service Pressure: 150 psig (10.3 bar)

See sizing charts on pages 5–7 for exact shutoff pressures

Max Service Temperature: 300°F (150°C)

Max Actuator Chamber Pressure: 90 psig (6.2 bar)

Corrosion Resistance: Resists alcohol, chloride and most caustic washdowns

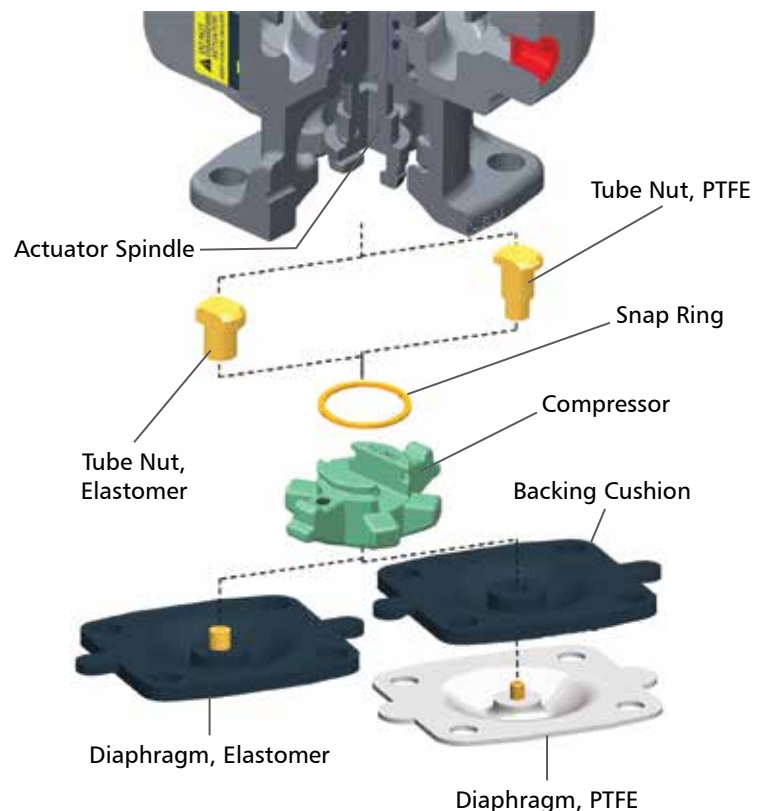
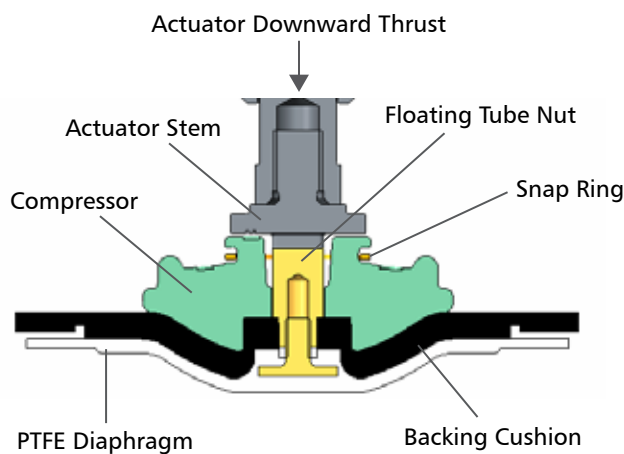

Note: Patent Pending Compressor Design

Identification and How to Order

Identification

An identification label is adhered to actuator and contains the following:

- Serial number
- Valve size
- Model number
- Maximum actuator chamber pressure rating

Separate label adhered to actuator indicates the mode of operation:

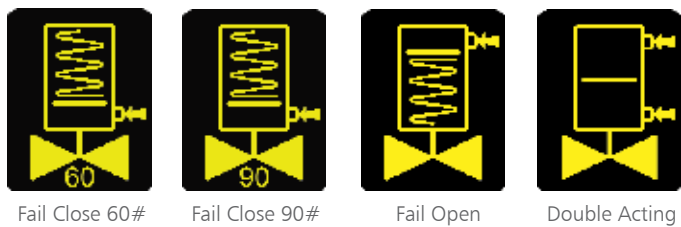
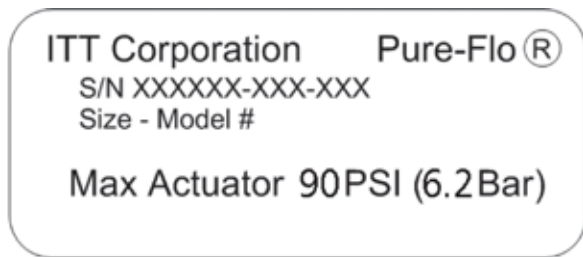

How to Order

Advantage® 2.1 Actuator

Code	Description
B105	Fail Open 0.5"
B108	Fail Open 0.75" or 1.0"
B116	Fail Open 1.5" or 2.0"
B205	Fail Close 0.50" with 60# Spring
B206	Fail Close 0.50" with 90# Spring
B208	Fail Close 0.50", 0.75" or 1.0" with 60# Spring
B209	Fail Close 0.75" or 1.0" with 90# Spring
B216	Fail Close 1.5" or 2.0" with 60# Spring
B217	Fail Close 1.5" or 2.0" with 90# Spring
B305	Double acting 0.5"
B308	Double acting 0.75" or 1.0"
B316	Double acting 1.5" or 2.0"

Example

0.5" (DN 15) body with tri-clamp ends 25 μ -in (0.6 μ m) ID, electropolish ID and OD, modified PTFE diaphragm with EPDM backing cushion, Advantage® 2.1 actuator.

Figure Number: .5-F-419-6-0-3-TME-B209

Configuration Example	.5	F	419	6	0	3	TME	B209
Valve Size	.5							
Body Type		F						
Body Ends			419					
Mechanical Polish - Interior				6				
Mechanical Polish - Exterior					0			
Electropolish						3		
Diaphragm							TME	
Actuator								B209

Weights and Dimensions

Dimensions

Valve Size		A Valve Open		C		D	
Inch	DN	Inch	mm	Inch	mm	Inch	mm
0.50	15	4.85	123.2	3.34	85	3.00	76
0.75	20	6.06	153.9	4.56	116	3.88	98
1.00	25	6.60	167.7	4.56	116	3.88	98
1.50	40	10.4	264.4	6.41	163	5.94	151
2.00	50	11.17	283.6	6.41	163	5.94	151

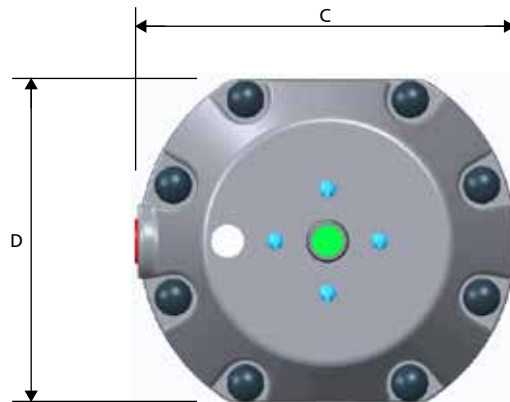
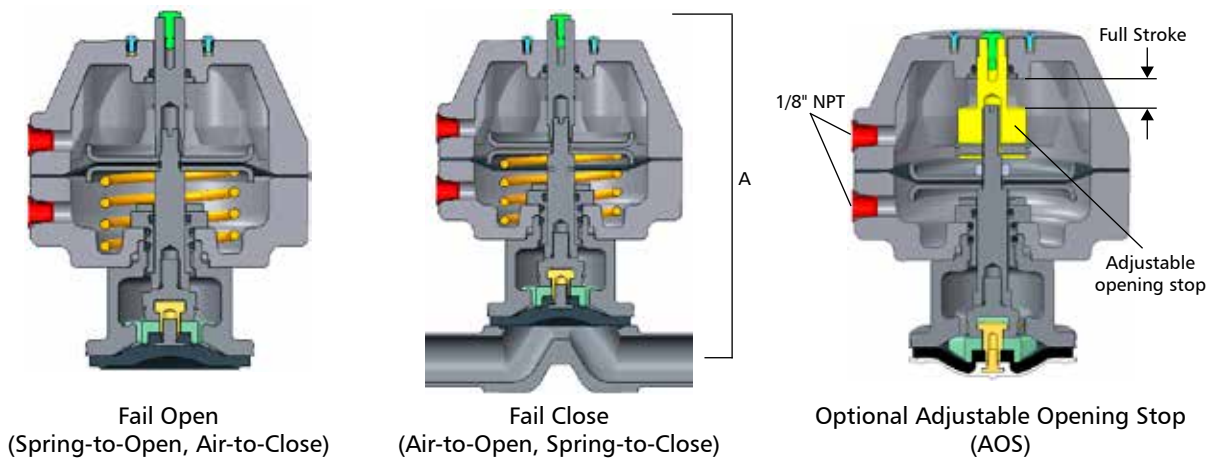

Actuator Weights (Less Body)

Valve Size		Double Acting		Fail Open		Fail Close	
Inch	DN	Lbs	Kg	Lbs	Kg	Lbs	Kg
0.50	15	2.00	0,91	2.09	0,95	2.34	1,06
0.75	20	3.69	1,67	3.78	1,71	4.34	1,97
1.00	25	4.47	2,03	4.59	2,08	5.16	2,34
1.50	40	12.10	5,49	12.60	5,71	16.44	7,46
2.00	50	15.16	6,88	15.66	7,10	19.50	8,84

¹ Bio-Tek sizes

Fail Close Actuator Sizing

Fail Close Actuators - Air-To-Open, Spring-To-Close (Reverse Acting)														
	Actuator and Spring Package	Maximum Line Pressure (psig)												Air pressure required to open for full stroke at 0 psi line pressure
		Valve Size												
		100% ΔP						0% ΔP						
		BT ²	.5"	.75"	1"	1.5"	2"	BT ²	.5"	.75"	1"	1.5"	2"	
Elastomer Diaphragm	B205 (60#)		110						90					50
	B206 (90#)		150						150					90
	B208 (60#)			100						60				45
	B208 (60#)				70						40			60
	B209 (60#)			150	150					120	85			90
	B216 (60#)					100						65		50
	B216 (60#)						70						30	60
B217 (90#)					150	150					130	75	90	
PTFE Diaphragm ¹	B203 (60#)	70						55						55
	B204 (90#)	150						125						75
	B206 (90#)		150						150					90
	B208 (60#)		150	140					100	70				60
	B208 (60#)				100						35			70
	B209 (90#)			150	150					80	80			90
	B216 (60#)					125						70		50
	B216 (60#)						60						45	60
B217 (90#)					150	150					125	70	90	

Fail Close Actuators - Air-To-Open, Spring-To-Close (Reverse Acting)														
	Actuator and Spring Package	Maximum Line Pressure (psig)												Air pressure required to open for full stroke at 0 psi line pressure
		Valve Size												
		100% ΔP						0% ΔP						
		BT ²	DN15	DN20	DN25	DN40	DN50	BT ²	DN15	DN20	DN25	DN40	DN50	
Elastomer Diaphragm	B205 (60#)		7,58						6,21					3,45
	B206 (90#)		10,34						10,34					6,21
	B208 (60#)			6,89						4,14				3,10
	B208 (60#)				4,83						2,75			4,14
	B209 (90#)			10,34	10,34					8,27	5,86			6,21
	B216 (60#)					6,89						4,48		3,45
	B216 (60#)						4,83						2,07	4,14
B217 (90#)					10,34	10,34					8,96	5,17	6,21	
PTFE Diaphragm ¹	B203 (60#)	4,83						3,79						3,79
	B204 (90#)	10,34						8,62						5,17
	B206 (90#)		10,34						10,34					6,21
	B208 (60#)		10,34	9,65					6,89	4,83				4,14
	B208 (60#)				6,89						2,41			4,83
	B209 (90#)			10,34	10,34					5,52	5,52			6,21
	B216 (60#)					8,62						4,83		3,45
	B216 (60#)						4,14						3,10	4,14
B217 (90#)					10,34	10,34					8,82	4,83	6,21	



Fail Open Actuator Sizing

Air Pressure Required to Close (psig)													
	Size	BT		.5"		.75"		1"		1.5"		2"	
	Actuator	B103		B105		B108		B108		B116		B116	
Elastomer Diaphragm	Line Pressure	% ΔP											
		100	0	100	0	100	0	100	0	100	0	100	0
	20	38	40	38	45	38	55	49	50	36	40	40	45
	40	40	42	40	50	42	60	52	61	38	44	45	50
	60	42	44	44	55	46	65	57	71	42	48	50	60
	80	46	48	48	60	50	70	61	80	44	52	56	70
	100	48	52	50	65	52	75	67	90	48	56	60	75
	125	52	56	54	70	60	85	73	-	50	60	64	80
	150	56	60	58	75	68	-	81	-	52	65	68	-
PTFE Diaphragm ¹	20	42	50	46	66	55	55	50	55	45	52	48	50
	40	44	52	50	68	58	60	55	60	50	56	50	60
	60	48	56	52	72	60	65	60	65	55	60	56	70
	80	52	60	56	76	65	70	65	70	60	64	64	80
	100	54	65	60	82	68	75	70	80	64	68	70	90
	125	58	70	64	86	74	80	75	-	68	72	76	-
	150	62	75	68	-	80	85	80	-	72	76	82	-

Air Pressure Required to Close													
	Size	BT		DN15		DN20		DN25		DN40		DN50	
	Actuator	B103		B105		B108		B108		B116		B116	
Elastomer Diaphragm	Line Pressure	% ΔP											
		100	0	100	0	100	0	100	0	100	0	100	0
	1,38	2,62	2,76	2,62	3,10	2,62	3,79	3,31	3,44	2,48	2,76	2,76	3,10
	2,76	2,76	2,90	2,21	3,45	2,70	4,14	3,58	4,20	2,62	3,03	3,10	3,45
	4,14	7,90	3,03	3,03	3,79	3,17	4,48	3,93	4,90	2,90	3,31	3,45	4,14
	5,52	3,17	3,31	3,31	4,14	3,45	4,83	4,20	5,57	3,03	3,56	3,86	4,83
	6,89	3,31	3,59	3,45	4,48	3,59	5,17	4,62	6,21	3,31	3,86	4,14	5,17
	8,62	3,59	3,86	3,72	4,83	4,14	5,86	5,03	-	3,45	4,13	4,41	5,52
	10,34	3,86	4,14	4,00	5,17	4,70	-	5,59	-	3,59	4,48	4,69	-
PTFE Diaphragm ¹	1,38	2,90	3,45	3,17	4,55	3,79	3,79	3,45	3,79	3,10	3,59	3,31	3,45
	2,76	3,03	3,59	3,45	4,70	4,00	4,14	3,79	4,14	3,45	3,86	3,45	4,14
	4,14	3,31	3,86	3,59	4,97	4,14	4,48	4,14	4,48	3,79	4,14	3,86	4,83
	5,52	3,59	4,14	3,86	5,24	4,48	4,83	4,48	4,83	4,14	4,41	4,14	5,52
	6,89	3,72	4,48	4,14	5,65	4,69	5,17	4,83	5,52	4,41	4,69	4,83	6,21
	8,62	4,00	4,83	4,41	5,93	5,10	5,52	5,17	-	4,69	4,97	5,24	-
	10,34	4,27	5,17	4,70	-	5,52	5,86	5,52	-	4,96	5,24	5,65	-

Double Acting Actuator Sizing

Air Pressure Required to Close (psig)												
Size	BT		.5"		.75"		1"		1.5"		2"	
Actuator	B103		B305		B308		B308		B316		B316	
Line Pressure	% ΔP											
	100	0	100	0	100	0	100	0	100	0	100	0
20	22	26	24	30	18	25	31	32	16	20	22	40
40	24	28	26	35	20	30	34	43	20	25	26	45
60	26	30	28	40	24	35	39	53	24	30	30	50
80	28	32	32	45	26	40	44	62	28	35	35	55
100	30	34	34	50	30	50	50	72	32	40	40	60
125	32	38	38	55	34	55	55	89	36	45	45	70
150	34	44	42	60	38	60	63	-	40	50	50	80
20	34	36	34	36	28	30	25	35	25	34	35	40
40	36	40	36	40	34	35	35	40	30	38	40	50
60	40	44	40	46	38	40	45	50	35	42	50	60
80	42	46	42	50	40	45	50	55	40	46	55	70
100	44	52	44	54	42	50	55	60	45	50	60	80
125	46	56	46	58	44	55	60	70	50	55	64	90
150	48	62	48	62	46	60	65	80	55	62	68	-

Air Pressure Required to Close												
Size	BT		DN15		DN20		DN25		DN40		DN50	
Actuator	B103		B305		B308		B308		B316		B316	
Line Pressure	% ΔP											
	100	0	100	0	100	0	100	0	100	0	100	0
1,38	1,51	1,79	1,65	2,07	1,24	1,72	2,14	2,21	1,10	1,38	1,52	2,76
2,76	1,65	1,93	1,79	2,41	1,38	2,07	2,34	2,97	1,38	1,72	1,79	3,10
4,14	1,79	2,07	1,93	2,75	1,65	2,41	2,69	3,66	1,65	2,07	2,07	3,45
5,52	1,93	2,21	2,21	3,10	1,79	2,76	3,03	4,27	1,93	2,41	2,41	3,79
6,89	2,07	2,34	2,34	3,45	2,07	3,45	3,45	4,96	2,21	2,76	2,76	4,14
8,62	2,21	2,62	2,62	3,79	2,34	3,79	3,79	6,14	2,48	3,10	3,10	4,83
10,34	2,34	3,03	2,90	4,14	2,62	4,14	4,34	-	2,76	3,45	3,45	5,52
1,38	2,34	2,48	2,34	2,48	1,93	2,07	1,72	2,41	1,72	2,34	2,41	2,76
2,76	2,45	2,76	2,76	2,48	2,34	2,41	2,41	2,76	2,07	2,62	2,76	3,45
4,14	2,76	3,03	2,76	3,17	2,62	2,76	3,10	3,45	2,41	2,90	3,45	4,14
5,52	2,90	3,17	2,90	3,45	2,76	3,10	3,45	3,79	2,76	3,17	3,79	4,83
6,89	3,03	3,57	3,03	3,72	2,90	3,45	3,79	4,14	3,10	3,45	4,14	5,52
8,62	3,17	3,86	3,17	4,00	3,03	3,79	4,14	4,83	3,45	3,79	4,41	6,21
10,34	3,31	4,27	3,31	4,28	3,17	4,14	4,48	5,52	3,79	4,28	4,69	-



Visit our website at
www.engvalves.com

