

PR Series Description Code

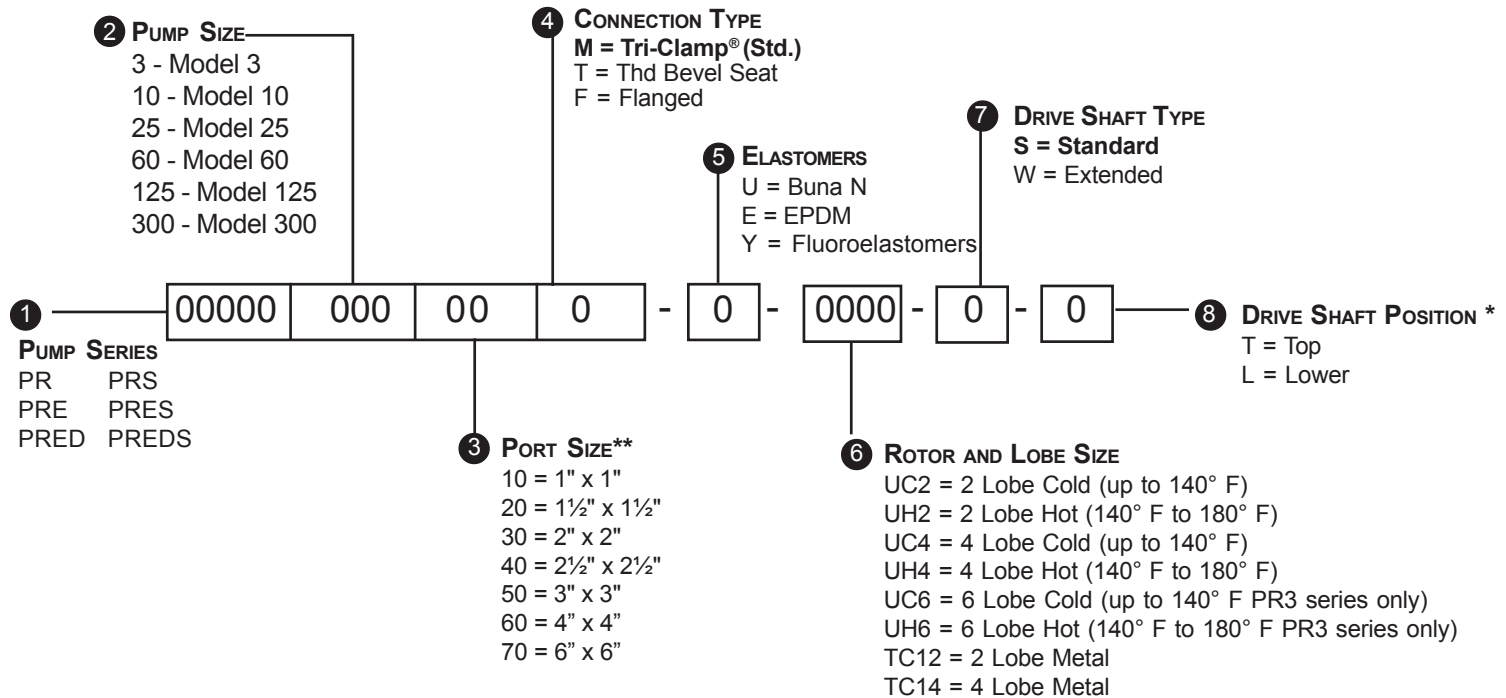

CSI 417.831.1411
csidesigns.com

① PRRED ② 125 ③ 20 ④ M - U - TC12 ⑤ - S - T ⑥ ⑦ ⑧



Notes:

** Refer to tables for port sizes available per model type.

*** Available only on 25 and 125 pumps.

† Springs available from 15 to 50 PSI and 50 to 100 PSI relief pressures.

*** Note:** On PRS/PRES Pumps,
T - Drive shaft on left side when facing the front of the pump
L - Drive shaft on right side when facing the front of the pump