

**Centrifugal Drum Pump Motor Models:
SP-8600, SP-8700, SP-8800 & SP-8900**

SP-8600 & SP-8700 Spare Parts List

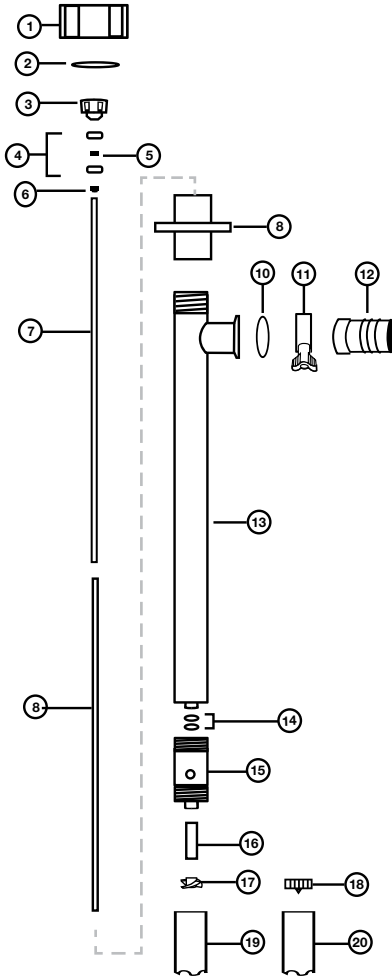

Reference Number	Description	Part Number for Model SP-8600	Part Number for Model SP-8700	Qty
1	Connection Nut, SS316L	8842	8842	1
2	Snap Ring, SS316L	8208	8208	1
3	Pump Coupling	1004	1004	1
4	Bearing	8838-2	8838-2	2
5	Bearing Spacer	8838-4	8838-4	1
6	Secondary Seal, PTFE	8803	8803	1
7	Drive Shaft, SS316L			
	39" (1000 mm)	8606	8606	1
	47" (1200 mm)	8607	8607	1
8	Guide Sleeve, PTFE			
	39" (1000 mm) / 47" (1200 mm)	8811	8811	1
9	Connection Flange, SS316L	8602	8602	1
10	O-Ring, Buna (Optional)	836	836	1
11	Tri-Clamp®, SS316L (Optional)	833	833	1
12	Hose Barb, SS316L, 1" (25 mm) (Optional)	8833	8833	1
13	Inner/Outer Tube Assembly, SS316L			
	39" (1000 mm)	8614	8614	1
	47" (1200 mm)	8615	8615	1
14	O-Ring, Buna (2 Required)	8823	8823	2
15	Pump Housing, SS316L	8824	8824	1
16	Bushing, PTFE	8825	8825	1
17	Impeller, High Volume, SS316L	8827	-	1
18	Impeller, High Pressure, SS316L	-	8927	1
19	Pump Foot, High Volume, SS316L	8826	-	1
20	Pump Foot, High Pressure, SS316L	-	8926	1

