

TrueClean ToteCleaner

Installation, Operation, and Maintenance Manual



TrueClean Check Valve

Table of Contents

- Introduction.....1
- About.....1
- Warranty.....2
- Safety.....3
- Important Safety Information.....3
- Components.....4
- Installation.....6
- Sequence of Operation.....8
- Maintenance.....12
- Spare Parts List.....14
- Customer Notes.....15

Introduction

About

Thank you for purchasing a TrueClean® product.

This manual contains installation, operation, and maintenance instructions for TrueClean's ToteCleaner™.

TrueClean ToteCleaners are designed to need little routine maintenance, but it is still important to read all instructions provided in this manual. The manual contains essential information regarding the ToteCleaner.

If you have questions or concerns regarding your ToteCleaner, please contact your TrueClean distributor.

Do not remove labeling on any TrueClean product. Immediately replace any label that is missing.

Introduction

Warranty

TrueClean (the "Seller") warrants its products to be free from defect in materials and workmanship for a period of one (1) year from the date of shipment. This warranty shall not apply to products which require repair or replacement due to normal wear and tear or to products which are subjected to accident, misuse, or improper maintenance. This warranty extends only to the original buyer. Products manufactured by others but furnished by the Seller are exempted from this warranty and are limited to the original manufacturer's warranty.

The Seller's sole obligation under this warranty shall be to repair or replace any products that the Seller determines, in its discretion, to be defective. The Seller reserves the right either to inspect the products in the field or to request their prepaid return to the Seller.

The Seller shall not be responsible for any transportation charges, duty, taxes, freight, labor, or other costs. The cost of removing and/or installing products which have been repaired or replaced shall be at the buyer's expense.

The Seller expressly disclaims all other warranties, express or implied, including without limitation any warranty of merchantability or fitness for a particular purpose. The foregoing sets forth the Seller's entire and exclusive liability, and the buyer's exclusive and sole remedy, for any claim of damages in connection with the sale of products. In no event shall the Seller be liable for any special consequential incidental or indirect damages (including without limitation attorney's fees and expenses), nor shall the Seller be liable for any loss of profit or material arising out of or relating to the sale or operation of the products based on contract, tort (including negligence), strict liability, or otherwise.

Safety

Read this entire manual carefully to learn how to install, operate, and maintain this equipment. Failure to do so could result in personal injury and/or equipment damage.

Safety Information

Do not attempt to modify any TrueClean product. Doing so could create unsafe conditions and would void all warranties.

Do not place any TrueClean product in an application where general product service ratings are exceeded.

The word **CAUTION** and its meaning, as used within these instructions, is defined below:

- **CAUTION:** Indicates a potentially hazardous situation which, if not avoided, may result in minor or moderate injury. This may also be used to alert against an unsafe operating or maintenance practice.

The word **DANGER** and its meaning, as used within these instructions, is defined below:

- **DANGER:** Indicates an imminently hazardous situation which, if not avoided, may result in serious injury or death. It is only used in extreme situations and warrants immediate action.

Components

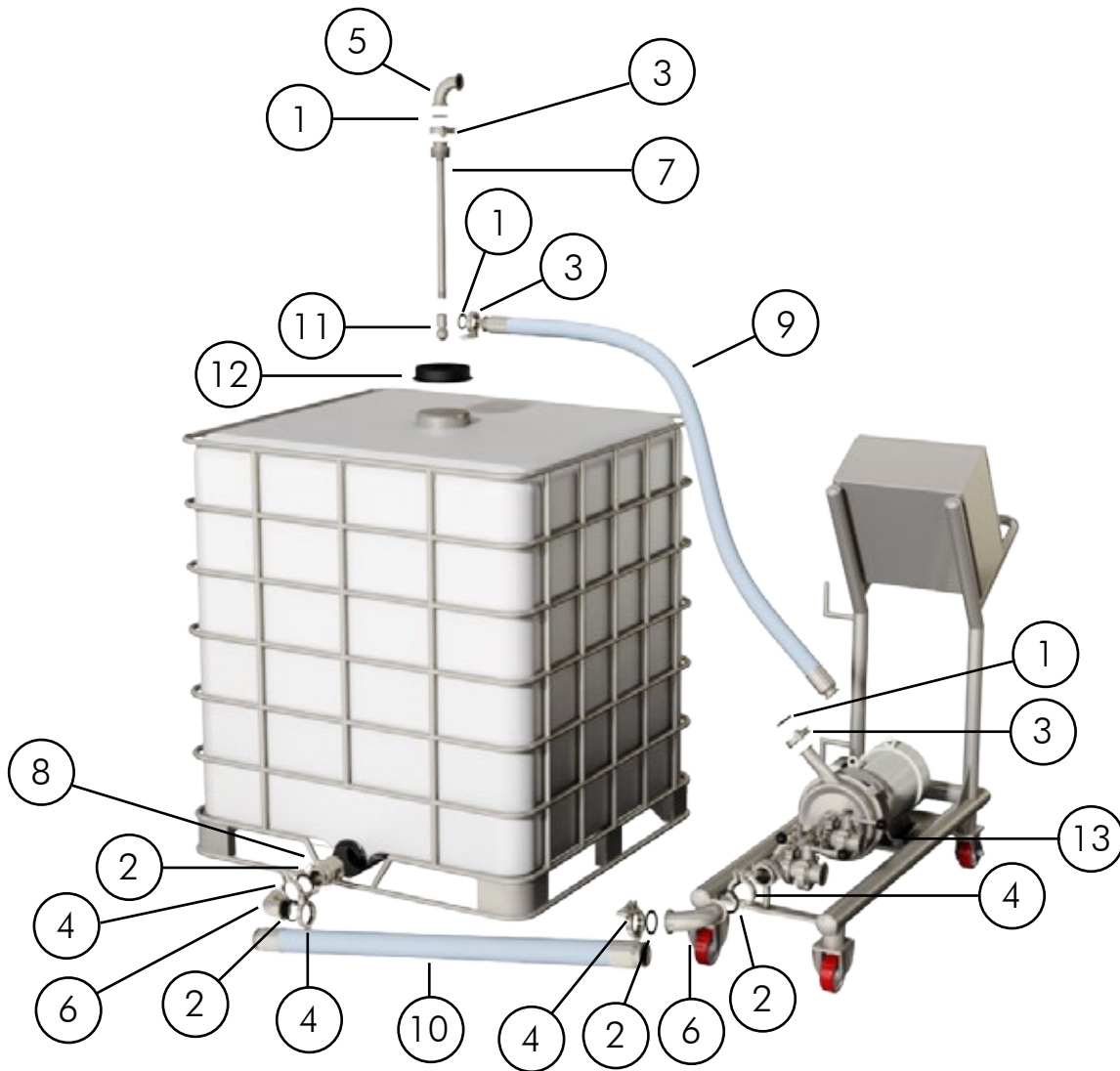

TRUECLEAN TOTE CLEANER S40 230V PARTS LIST			
ITEM	QTY	PART NUMBER	DESCRIPTION
1	3	40MPE-1.5	GASKET, 1.5" TC , EPDM USP CLASS VI
2	4	40MPE-2	GASKET, 2" TC , EPDM USP CLASS VI
3	3	A13MHM-1.5	CLAMP HEAVY, TWO PIECE, 1.5" TC
4	4	A13MHM-2-S	CLAMP HEAVY, TWO PIECE, 2" TC
5	1	B2CMP-1.5-316L-7	ELL 90 1.5" TC 316L 32RA ID 32RA OD
6	2	B2CMP-2-316L-7	ELL 90 2" TC 316L 32RA ID 32RA OD
7	1	CS000193	DOWNTUBE TT 1.5" TC X 0.75" MPT 18.5" OAL 316L SHOP USE ONLY
8	1	CS00670	ADAPTER 2" FEMALE CAMLOCK X TC MFG ITEM 316L 3.65" OAL
9	1	RSD150TC150TC150	HOSE ASSEMBLY RUBBER 1.5" ID 1.5" TC 6'
10	1	RSD200TC200TC200	HOSE ASSEMBLY RUBBER 2" ID 2" TC 4'
11	1	TCT-S40-360-N6-316L	ROTARY SPRAY HEAD S40 360° 3/4" FPT 316L TRUECLEAN
12	1	TTC0004	BANJO 6" IBC TANK LID 2" PLUG W/ EPDM GASKET
13	1	TTC-CRT-3.0-230	TOTE CLEANER PUMP CART 3HP 230V

To purchase spare parts please contact your TrueClean distributor.

Components

Electrical Panel

Become familiar with the control panel functions before operating the ToteCleaner. The following glossary defines objects found on the control panel.

- **START** - turns the pump on once the system is completely installed and digital timer is set. It also resets the time, if pressed before the time is complete.
- **STOP** - shuts the pump off. This can be done while the timer is still running or during a wash with an undetermined amount of time.
- **E-STOP** - shuts pump off in case of emergencies. The **E-STOP** is wired directly to the pump, so pushing the **E-STOP** will leave the timer unaffected. The **STOP** button will restart the time if pressed.
- **ELECTRICAL DISCONNECT** - disconnects all incoming power to the panel. It must be turned off before opening the panel.

DANGER: Failure to power down equipment can lead to personal injury or death. Always make sure that the electrical supply is powered down before opening the electrical enclosure.

- **DIGITAL TIMER** - used to regulate run time of the pump. Upon completion of selected time, the pump will shut off and put the system on hold.

▲ **UP** and ▼ **DOWN** arrows - set run times.

↻ **LOOP** arrow - enters the selected time.

- **F1/RST** - starts the pump. It works identically to the **START** button.

Important Notes:

- The last selected run time is displayed on the timer upon startup, even if it was previously powered down or shut off.
- To change the timer setting while the pump is running, use the **UP** and **DOWN** buttons to select the desired time. Enter the new time by pressing the **LOOP** arrow.
- By setting a time of zero and pressing **START**, the pump will run indefinitely until the **STOP** button or **E-STOP** is hit.

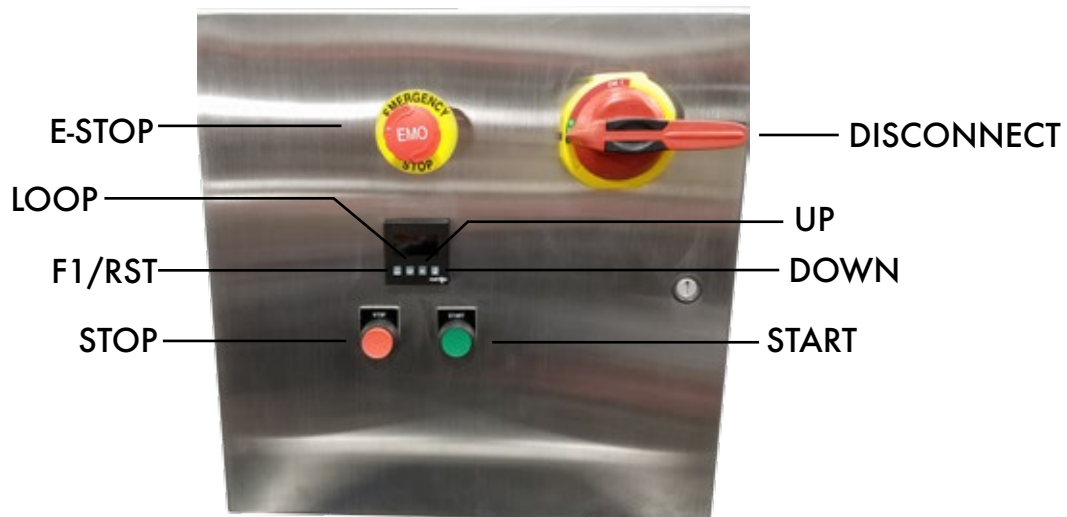

Installation

Spray Assembly Instructions

1. Apply anti-seize to threads on spray tube.
2. Attach spray tube onto lid by threading it into the center bung. Be careful not to over-tighten, as this could damage the bung.
3. Attach the provided cleaning device by screwing it onto the spray tube. Secure with an open-ended or adjustable wrench.
 - a. Tighten, using the flats nearest the threads. Using the flats on the lower body can cause damage to the device.
 - b. For full assembly, please refer to Figure 1.



Figure 1

Installation

1. Confirm that the tote is drained of all flowing product.
2. Confirm that the tote to be cleaned is elevated at least seven inches off the floor.
3. Confirm that the ToteCleaner cart is on a structurally sound, flat, and level surface.
4. Screw spray assembly into large opening on the top of the tote.
5. Connect 1.5" elbow to spray assembly with provided gasket and clamp.
6. Connect 1.5" supply hose to elbow with provided gasket and clamp.
7. Connect supply hose to pump outlet with provided gasket and clamp.
8. Attach Camlock by Tri-Clamp adapter to the tote outlet drain.
9. Connect 2" elbow to the adapter with provided gasket and clamp.
10. Connect 2" elbow to the return port on the cart with provided gasket and clamp.
11. Connect 2" return hose from elbow on the tote outlet to the elbow on the cart.
12. Connect water supply to supply port on cart with provided gasket and clamp.
13. Connect drain hose to drain port with provided gasket and clamp. Run the hose to a safe place to drain.
14. Plug the power cord into appropriate power supply, as labelled on the control panel.
15. If appropriate, switch disconnect on remotely mounted electrical panel to **ON**.

Sequence of Operation

The TrueClean ToteCleaner is designed to allow versatility in the washes that can be performed.

If cleaning needs are minimal, a rinse wash may be run by following the **Rinse Wash** sequence of operation.

If the use of chemicals is desired, a caustic or acid wash may be run by following the **Caustic/Acid Wash** sequence of operation. If both a caustic and an acid wash are desired, repeat the sequence of operation outlined under **Caustic/Acid Wash**. The steps for each are identical.

If a sanitizer wash is desired, follow the **Sanitizer Wash** sequence of operation.

Below are examples of common wash recipes.

Caustic wash: Initial rinse • Caustic wash • Post rinse

Caustic wash with sanitizer: Initial rinse • Caustic wash • Post rinse • Sanitizer wash

Caustic/acid wash: Initial rinse • Caustic wash • Post rinse • Acid wash • Post rinse

Caustic/acid wash with sanitizer: Initial rinse • Caustic wash • Post rinse • Acid wash
Post rinse • Sanitizer wash

Sequence of Operation

Rinse Wash

1. Close recirculation valve, and open supply and drain valves.
 - a. Please refer to Figure 2 for valve configuration.
2. Confirm that there is water flowing to the supply valve.
3. Set desired wash time on electronic timer, and press **ON** button to start the pump.
4. After time is complete the timer will shut the pump off automatically. Next, close the supply valve and allow the tote to completely drain.
 - a. If a rinse wash is the only wash to be run, also open the recirculation valve to allow the pump and supply hose to drain with the tote.
 - i. Please refer to Figure 3 for valve configuration.

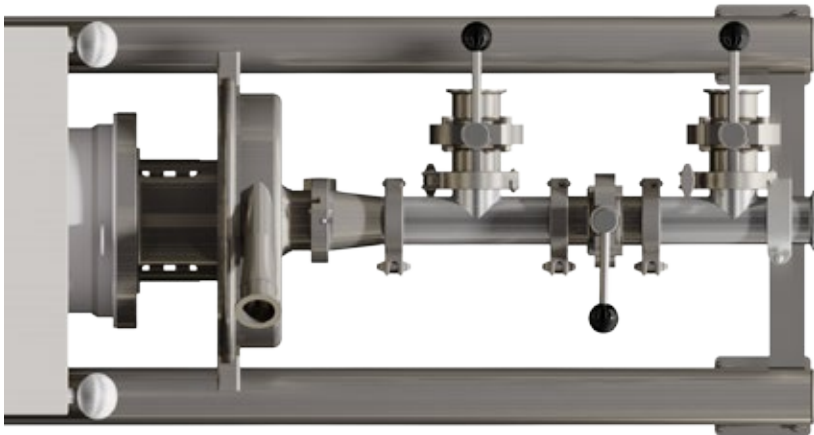

Figure 2

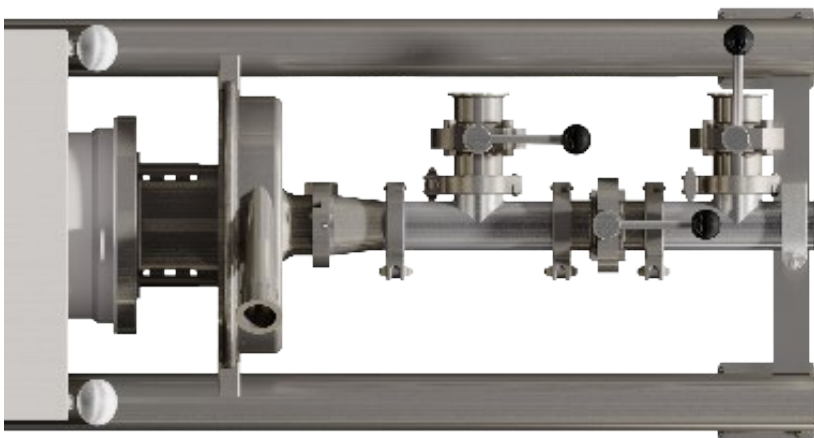

Figure 3

Sequence of Operation

Caustic/Acid Wash

5. Close drain valve. Open recirculation and supply valves, allowing water to fill the tote.

a. Please refer to Figure 4 for valve configuration.

6. Monitor water level until there are four to six inches of water in the bottom. Close the supply valve, taking care to leave the recirculation valve open.

a. Please refer to Figure 5 for valve configuration.

7. Disconnect the elbow at the spray assembly, unscrew the spray assembly, and dose caustic solution into the tote through the lid connection.

a. **CAUTION:** Personal protective equipment (PPE) should be used when handling hazardous chemicals to protect the operator and/or bystanders from chemical contact.

b. Please refer to Figure 6 as an example of proper dosing procedure.

8. Screw spray assembly back onto lid connection, and reattach elbow.

9. Set desired wash time on electronic timer, and press **ON** button to start pump.

10. After time is complete the timer will shut the pump off automatically. Next, open the drain and recirculation valves. Allow the tote to completely drain.

a. Please refer to Figure 3 for valve configuration.

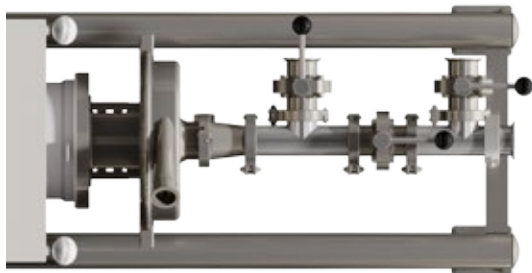

Figure 4

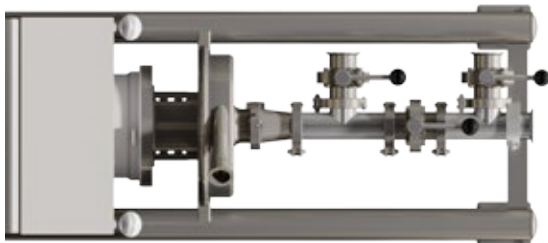

Figure 5



Figure 6

Sequence of Operation

Sanitizer Wash

1. Close drain valve. Open recirculation and supply valves, allowing water to begin filling the tote.
 - a. Please refer to Figure 4 for valve configuration.
2. Monitor water level until there are four to six inches of water in the tote, then close the supply valve, taking care to leave the recirculation valve open.
 - a. Please refer to Figure 5 for valve configuration.
3. Disconnect the elbow at the spray assembly, unscrew the spray assembly, and dose sanitizer solution into the tote through the lid connection.
 - a. **CAUTION:** Personal protective equipment (PPE) should be used when handling hazardous chemicals to protect the operator and/or bystanders from chemical contact.
 - b. Please refer to Figure 6 as an example of proper dosing procedure.
4. Screw the spray assembly back onto lid connection, and reattach elbow.
5. Set desired wash time on electronic timer, and press **ON** button to start pump.
6. After time is complete, the timer will shut the pump off automatically. Close the supply valve and open the recirculation valve to allow the tote and hoses to completely drain.
 - a. Please refer to Figure 3 for valve configuration.

Upon completion of the final wash power down, close all valves and disconnect all hoses from the tote.

Maintenance

It is advised that preventative maintenance be performed periodically throughout the lifetime of this system to ensure longevity and maintain efficiency. There are four items that are maintainable on this system: pump, butterfly valves, spray device (excluding the S40), and all Tri-Clamp gaskets.

The manuals and maintenance procedures for the pump, butterfly valves, and spray device can be found on the included thumb drive bracelet.

Centrifugal pump maintenance can be found on pages 14-22 of Alfa Laval SolidC Pump Manual.

The recommended maintenance schedule can be found below in Figure 7.

	Shaft seal	Rubber seals	Motor bearings
Preventive maintenance	Replace after 12 months: (one-shift) Complete shaft seal	Replace when replacing the shaft seal	
Maintenance after leakage (leakage normally starts slowly)	Replace at the end of the day: Complete shaft seal	Replace when replacing the shaft seal	
Planned maintenance	<ul style="list-style-type: none"> - Regular inspection for leakage and smooth operation - Keep a record of the pump - Use the statistics for inspection planning Replace after leakage: Complete shaft seal	Replace when replacing the shaft seal	Yearly inspection is recommended <ul style="list-style-type: none"> - Replace complete bearing if worn - Ensure that the bearing is axially locked (See motor instructions)
Lubrication	Before fitting Lubricate the O-rings with silicone grease or silicone oil	Before fitting Silicone grease or silicone oil	The bearings are permanently lubricated

Figure 7: Pump Maintenance Schedule

Maintenance

Butterfly valve maintenance can be found on pages 17-25 of Alfa Laval LKB Butterfly Valve Manual. The recommended maintenance schedule can be found below in Figure 8.

	Valve seal rings	Valve bushes	Actuator rubber seals	Actuator bearings
Preventive maintenance	Replace after 12 months	Replace when replacing the valve seal rings	Replace after 24 months	
Maintenance after leakage (leakage normally starts slowly)	Replace by the end of the day	Replace when replacing the valve seal rings	Replace when possible	
Planned maintenance	<ul style="list-style-type: none"> - Regular inspection for leakage and smooth operation - Keep a record of the valve - Use the statistics for inspection planning <p>Replace after leakage</p>	Replace when replacing the valve seal rings	<ul style="list-style-type: none"> - Regular inspection for leakage and smooth operation - Keep a record of the actuator - Use the statistics for planning of inspections <p>Replace after air leakage</p>	Replace when they become worn
Lubrication	<p>Before fitting (use USDA-H1 approved)</p> <ul style="list-style-type: none"> - Unisilcon L641(*) - Paraliqu(*) GTE 703 - Molycote 111(D) 	None	<p>Before fitting</p> <ul style="list-style-type: none"> - Molycote Long term 2 Plus (Δ) - Molycote 1132(Δ) (for aggressive environment) 	<p>When replacing actuator rubber seals</p> <ul style="list-style-type: none"> - Molycote Long term 2 Plus (Δ) - Molycote 1132 (Δ) (for aggressive environment)

Figure 8: Butterfly Maintenance Schedule

CP2 spray device maintenance can be found on pages 38-52 of AWH CP2 Manual.

JM100 spray device maintenance can be found on pages 47-72 of AWH JM100 Manual.

The Tri-Clamp gaskets should be replaced once every three to six months. If it is found that the gaskets are failing prior to three months, replace gaskets accordingly.

Maintenance

Spare Parts List

Item	Part Number	Quantity
Manual Butterfly Valve Kit	9611923030	3
Pump Mechanical Seal- 3 and 7.5 hp Models	9612129609	1
Pump Cover Gasket- 3 hp Model	9611994241	1
Pump Cover Gasket- 7.5 hp Model	9611994245	1
CP2 Wearing Parts Kit	66901000V0000	1
JM100 Wearing Parts Kit	66901000V0000	1
IBC Tote Lid	TTC0004	1
Sanitary Hose- 1.5"	RSD150TC150TC150-72	1
Sanitary Hose- 2"	RSD200TC200TC200-48	1
Sanitary Ferrule Gasket- 1.5"	40MPE-1.5	3
Sanitary Ferrule Gasket- 2"	40MPE-2	9
Sanitary Ferrule Gasket- 2.5"	40MPE-2.5	1
Sanitary Ferrule Clamp- 1.5"	A13MHM-1.5-S	3
Sanitary Ferrule Clamp- 2"	A13MHM-2-S	9
Sanitary Ferrule Clamp- 2.5"	A13MHM-2.5-S	1

To purchase spare parts please contact your TrueClean distributor.

Customer Notes